

**10<sup>th</sup> Competition**

**SAE BRASIL AeroDesign**

***Regular and Open Classes***

***Competition Regulations***

Prepared by the Competition Technical Committee

February 25, 2008

## Tips on reading this document

### Part I

**Opening Section:** This information is general in nature, covering Competition objectives, deadlines, and tips.

It is important that everyone on the team be aware of the contents of this Section.

Item 6 is for Faculty Advisers.

### Part II

**Introduction:** General aspects of AeroDesign in Brazil.

**Chapter 1:** Initial requirements. Valid for the Regular and Open Classes.

**Chapter 2:** Project Requirements valid ONLY for the Regular Class.

**Chapter 3:** Project Requirements valid ONLY for the Open Class.

**Chapter 4:** Mission Requirements. Valid for both the Regular and Open Classes.

**Chapter 5:** General Rules for Reports and Presentation (Design Competition). Valid for both the Regular and Open Classes.

**Chapter 6:** Appendixes: Regular and Open Classes.

## Index

<b>PART I</b> .....	<b>I</b>
<b>1. Introduction</b> .....	<b>II</b>
<b>2. Competition Objectives</b> .....	<b>III</b>
<b>3. General Information</b> .....	<b>III</b>
<b>4. General Rules</b> .....	<b>IV</b>
<b>5. Tips</b> .....	<b>VIII</b>
5.1. Important documents.....	VIII
5.2. Important Dates.....	IX
<b>6. Role of the Faculty Adviser*</b> .....	<b>X</b>
Pedagogical Techniques.....	XII
MEC Guidelines .....	XIII
<b>PART II</b> .....	<b>1</b>
<b>INTRODUCTION</b> .....	<b>3</b>
<b>1. Shared Requirements – Open and Regular Classes</b> .....	<b>6</b>
1.1. Objective and Scope .....	6
1.2. Project Objective .....	6
1.3. Competition organization.....	6
1.4. Outside help .....	7
1.5. Pilot requirements .....	7
1.6. Registration Fee .....	8
1.7. Entering several airplanes from the same educational institution .....	8
1.8. Airplane configuration.....	9
1.8.1. Airplane type and restrictions (Open and Regular Classes) .....	9
1.8.2. Reusing the airplane .....	10
1.9. Modifications and Nonconformities – Loss of Points .....	11
1.9.1. Project Modifications.....	11
1.9.2. Nonconformity with the rules.....	12
1.10. Airplane identification .....	12
1.10.1. Team number .....	12
1.10.2. Name of the educational institution .....	12
1.11. Complaints, Protests and Suggestions .....	13
1.11.1. Complaints and Protests .....	13
1.11.2. Suggestions.....	14
<b>2. Requirements – Regular Class</b> .....	<b>15</b>
2.1. Eligibility – Team members .....	15
2.2. Geometric Restrictions (“Four-Dimensional Hangar” <sup>(1)</sup> ) .....	15
2.2.1. Basic Requirements .....	15
2.2.2. Additional observations .....	17
2.2.3. Construction Quality (or Dimensional Precision).....	18
2.3. Required engine .....	19
2.4. Gear boxes, belts and propeller shafts.....	19
2.5. Cargo Compartment (or Payload Bay) Limits.....	19
2.5.1. “Payload Group” Distribution.....	20
2.5.2. “Payload” and “Payload Assembly Section” .....	21
2.6. Gyroscopes .....	22
2.7. Additional Requirements – Regular Class.....	22
2.7.1. Radio Control .....	22
2.7.2. Battery pack .....	23

2.7.3.	VoltWatch installation .....	23
2.7.4.	Engine inspection .....	24
2.7.5.	Propellers .....	24
2.7.6.	Fuel and Fuel Tank .....	24
2.7.7.	Use of a Tail chute or Parachute .....	25
2.7.8.	Control Surfaces .....	25
2.7.9.	Servo Sizing .....	25
2.7.10.	Flight Video (bonus) and Qualifying Flights .....	25
2.7.11.	Maximum Eligible Weight .....	26
2.8.	Takeoff Distance – Regular Class .....	26
2.8.1.	Introduction .....	26
2.8.2.	“Segmented Runway Concept” .....	26
2.9.	Points – Regular Class .....	27
2.9.1.	Maximum Payload Flight Score .....	27
2.9.2.	Accuracy – Points .....	27
2.9.3.	Structural Efficiency Factor – Additional Points .....	28
2.9.4.	“Quick Payload Removal” – Additional Points .....	29
2.9.5.	“Minimum Volume Box” – Additional Points .....	29
<b>3.</b>	<b>Requirements – Open Class .....</b>	<b>31</b>
3.1.	Eligibility – Team members .....	31
3.2.	Engine .....	31
3.3.	Gear boxes, belts and propeller shafts .....	32
3.4.	Payload Group (or “Useful Load”) .....	32
3.5.	Gyroscopes .....	32
3.6.	Fuel and Fuel Tank .....	32
3.7.	Specific Safety Requirements .....	33
3.7.1.	Radio Control .....	33
3.7.2.	Receiver and Battery Packs .....	34
3.7.2.1.	Receiver .....	34
3.7.2.2.	Battery packs .....	34
3.7.3.	Additional Requirements – Electronic Systems .....	35
3.7.4.	Additional Requirements – In General .....	36
3.7.5.	Single-engine flight test .....	36
3.7.6.	Flight Video .....	36
3.7.7.	Qualifying Flights .....	37
3.7.8.	Project Follow-up and Validation .....	37
3.7.9.	Propellers .....	38
3.7.10.	Use of a Tail chute or Parachute .....	38
3.7.11.	Control Surfaces .....	38
3.7.12.	Servo Sizing .....	39
3.7.13.	Maximum Eligible Weight .....	39
3.8.	Takeoff Distance – Open Class .....	39
3.8.1.	Takeoff Distance .....	39
3.8.2.	Important Operational Aspects – Open Class .....	39
3.9.	Scoring – Open Class .....	40
3.9.1.	Payload Ratio .....	40
3.9.2.	Accuracy .....	40
3.9.3.	“Quick Payload Removal” (only for Regular Class) .....	40
3.9.4.	Empty Weight Flight Bonus – Bonus .....	41
<b>4.</b>	<b>Mission Requirements – Regular and Open Classes .....</b>	<b>42</b>
4.1.	Flight Competition .....	42
4.1.1.	Safety Inspections .....	42
4.1.2.	Weighing Process .....	43

4.1.3.	Aircraft Maximum Dimensions and Cargo Bay Verification.....	43
4.1.4.	Qualifications.....	43
4.1.5.	Standard Flight (totally valid flight).....	44
4.1.6.	Landing .....	45
4.1.7.	Airplane condition after landing.....	46
4.1.8.	Alterations and Repairs.....	46
4.1.9.	Additional Flight Considerations.....	47
4.1.9.1.	Flight Order.....	47
4.1.9.2.	Takeoff Time.....	48
4.1.9.3.	“Useful Load” .....	48
4.1.9.4.	Fuel (Regular Class).....	48
4.1.9.5.	Test Flight.....	49
4.1.10.	Final Round .....	49
4.2.	Scoring .....	49
4.2.1.	Overall Score .....	49
4.2.1.1.	Design Competition .....	49
4.2.1.2.	Flight Competition.....	49
4.3.	Penalty Scenarios .....	50
4.3.1.	Penalties .....	50
4.4.	Overall Conduct and Safety .....	52
4.5.	Notes .....	54
<b>5.</b>	<b>General Rules – Report and Presentation .....</b>	<b>55</b>
5.1.	Design Competition.....	55
5.1.1.	Design Report .....	55
5.1.1.1.	Report format and limitations.....	56
5.1.1.2.	Attachments and Appendixes.....	58
5.1.2.	Plans .....	58
5.1.2.1.	Plans – Regular Class – General Information .....	58
5.1.2.2.	Additional Plans – Information for the Dimensional Inspection .....	59
5.1.2.3.	Additional Plans – Aircraft Disassembled in the Box.....	60
5.1.2.4.	Plans – Open Class.....	60
5.1.3.	Summary – Required Documents.....	61
5.1.4.	Estimated “Useful Load” – Accuracy.....	62
5.1.4.1.	Estimated Useful Load for Two <i>Sections</i> – Regular Class.....	63
5.1.5.	Report Delay Penalties .....	64
5.1.6.	Notes on Delivering the Reports: .....	64
5.1.7.	Report Structure Model.....	65
5.1.8.	Oral Presentation .....	65
<b>6.</b>	<b>APPENDIXES.....</b>	<b>67</b>
	APPENDIX – 6.1A: EXAMPLE OF “ASSEMBLY SECTION” AND “PAYLOAD”.....	68
	APPENDIX – 6.1B: “PAYLOAD ASSEMBLY SECTION” – Example.....	69
	APPENDIX – 6.1C: ADDITIONAL EXPLANATIONS – Cargo Compartment.....	70
	APPENDIX – 6.2: SAMPLE GRAPH OF ESTIMATED “USEFUL LOAD”.....	73
	APPENDIX – 6.3: DRAWING IN THREE VIEWS .....	74
	APPENDIX – 6.4A: GEOMETRIC RESTRICTIONS: Additional Information .....	75
	APPENDIX – 6.4B: IDENTIFYING THE “GROUPS OF AERODYMANIC SURFACES” – Aircraft Examples.....	77
	APPENDIX – 6.4C: THREE ADDITIONAL VIEWS – Dimensional inspection .....	79
	APPENDIX – 6.5: THREE ADDITIONAL VIEWS – “Minimum Volume Box”. .....	80
	APPENDIX – 6.6: STATEMENT OF RESPONSABILITY .....	81
	APPENDIX – 6.9: DECLARATION THAT THE AIRPLANE ALREADY FLEW .....	84
	APPENDIX – 6.10: EXAMPLE OF THE DESIGN REPORT STRUCTURE.....	85

# PART I

## 1. Introduction

In 1999, the first edition of the SAE AeroDesign Competition was held in Brazil. Since then, the Brazilian Competition has gradually grown, in terms of the number of teams and its technical quality. Around 10 teams participated in the first edition but, in 2006, a record number of 78 teams were registered. In 2007, there were approximately 70 teams, which showed an even higher technical level than the 2006 edition. This result indicates the enormous technical and organizational capacity that the participating teams have, in the face of the challenges put forth, giving the Technical and Organizing Committee of SAE AeroDesign constant reason to celebrate.

In 2008, the 10<sup>th</sup> SAE AeroDesign Competition will be held in Brazil. The event is seen to be extremely important and should consolidate the Competition, right here in Brazil, on an international level, always marked by a great spirit of sportsmanship, solidarity among the competitors and, of course, a very high technical level. Throughout these ten years, one of the main objectives of the Technical Committee has always been an active contribution to the professional formation of all of the participants. This preparation is not only in the technical field, which is guaranteed by ever-growing challenges found in the Regulations, but also in the organizational aspects, through the basic and highly important “teamwork”, so important to today’s engineering scenario.

This tenth edition should be marked by not only new and even more challenging Regulations for the Regular Class, but also by an expected greater participation by foreign teams.

We hope that this Competition will be memorable, not only for its commemoration of the tenth anniversary of the SAE AeroDesign Competition – Brazil, but especially for consolidating an image that has grown over the past several years during the Competitions held here. This image is formed by competence, knowledge, solidarity, friendship and, as already cited, a very high technical level. The Committee is honored and pleased to prepare bigger challenges for the teams, because one fact is always on our minds: they will be increasingly better resolved.

As of 2008, the three main documents for SAE AeroDesign to be released in the early months of the year are:

- **Regulations for SAE AeroDesign 2008:** The document enumerates all of the requirements that guide the aircraft projects in two Classes: Regular Class and Open Class. All of the items that describe the operational aspects that do not affect the project itself were transferred to the following document:
- **Operational Procedures – SAE AeroDesign 2008:** This deals with all of the actual operational aspects of the SAE AeroDesign 2008 Competition that do not directly affect the aircraft project. All of the checking, flight and post-flight evaluations of the participating aircraft are explained, here, in detail. It is a document that seeks, primarily, to maximize the number of competing rounds, by previously publicizing the processes (or procedures) of the Competition. Once this is known by everyone, the Competition can be carried on much easier.
- **Safety Regulations and Good Practices – SAE AeroDesign 2008:** The document is divided into two parts, that is, mandatory items (“Regulations”) and recommended items (“Good Practices”). The mandatory items deal, basically, with the electronic

installation and any eventual inspection processes of the structural integrity. This document is formed by lessons learned throughout 10 editions of the Competition in Brazil and its only objective is to guarantee greater safety for all of those present, with safe aircraft.

For this present document (Regulations of the SAE AeroDesign Competition), a series of additional comments and explanations, **highlighted in yellow**, are found here, and the objective is to assist the teams with a greater amount of information, so that the Regulations are understood, leaving no room for misunderstandings or doubts.

This document is composed of the Regulations for the 10<sup>th</sup> SAE BRASIL AeroDesign Competition, together with the additional comments and clarifications for the teams and Faculty Advisers.

All of the items described in this document are mandatory in nature.

## 2. Competition Objectives

- Provide a unique learning opportunity in the field of aeronautics via a challenging multi-disciplinary project;
- Awaken interest in the field of aeronautics;
- Foment technical and knowledge exchange between the teams;
- Develop a spirit of teamwork;
- Develop leadership and planning capabilities;
- Develop a capacity for selling ideas and projects;
- Give incentive to ethical and professional behavior.

## 3. General Information

The teams should be formed by engineering, physics or aeronautical sciences students associated with SAE BRASIL, plus a Faculty Adviser. There is no maximum number of participants per team.

Registration must be done via the form found at SAE BRASIL's site:  
[www.saebrasil.org.br](http://www.saebrasil.org.br).

**Reports should be sent to:**

**José Fernando David Farat**  
**EMBRAER – VED / DSE / GI9 PC 332**  
**Av. Brigadeiro Faria Lima, 2170**  
**CEP 12227-901**  
**São José dos Campos – SP, Brasil**



## 4. General Rules

- 1) Decisions made with flexibility in previous Competitions might not be made in this Competition. The teams will be informed, in good time, regarding all decisions, procedures and/or changes that may occur throughout 2008. An explanatory document regarding all of the operational aspects of the Competition (“*Operational Procedures – SAE AeroDesign 2008*”) will be released in good time.

**All of the procedures to be adopted have only to do with the Competition of the current year, that is, 2008. It cannot be expected that the rules, procedures or decisions of 2007 will also be applied in 2008. These could be different.**

- 2) The teams may be formed by several students, but for financial or logistical reasons SAE BRASIL may restrict the participation of all students in some of the events, if necessary, and may restrict the number of meal tickets, lodgings and T-shirts. In all of these cases, the students will be duly informed as far in advance as possible. All of the team members will receive a Certificate for participating.
- 3) With no intention of jeopardizing any of the teams, but, rather, to allow the Competition to proceed more smoothly, any aspect of the Regulations may be changed by the Organizing Committee before or during the Competition, if the committee considers it to be necessary. These changes will be communicated at the proper time and, when possible, the team captains will be consulted. It is the intention of the Technical Committee that any modification made after the release of the Regulations does not affect the projects already being developed. A modification that might interfere in the project philosophy adopted by the team will be made only in the case of extreme necessity or for the purpose of improving the safety of the aircraft.
- 4) SAE BRASIL is not liable for the people participating in the event. All of those registered will be required to sign a Liability Release at the reception desk. Medical and accident insurance are totally the responsibility of the participants. For this reason, it is EXPRESSLY PROHIBITED to smoke and consume alcoholic beverages within the Competition area (Remember that the food court is also a part of the Competition area).
- 5) Any questions regarding the Competition and/or sending the files required by the regulations must be sent to SAE BRASIL. The contacts must be made with Vanessa Viana, on the staff of the Central Office of SAE BRASIL, in São Paulo, via E-mail: [vanessa.viana@saebrasil.org.br](mailto:vanessa.viana@saebrasil.org.br), who will forward them to the Technical Committee, when necessary:

The most common questions are about:

- Technical issues, reusing the airplane, project changes, or delivering Reports.
- Issues regarding registration and the organization of the event: SAE BRASIL.

We suggest that the subject line of the E-mails sent be filled in, as follows:

Team XX – Technical Question – [*Subject of the doubt*]

Team XX – Reuse of the Airplane

Team XX – Project Change

Team XX – Open Class Analysis Report

Team XX – Question – [*Subject of the doubt*]

This suggestion is very helpful to the Committee in organizing the information pertaining to the 10<sup>th</sup> SAE AeroDesign Competition. The questions will be answered as soon as

possible. We recommend that the questions be sent only by E-mail. The answers to the questions will also be returned by E-mail. *Questions and answers by telephone can lead to misunderstandings and incorrect interpretations, which cannot be checked later.*

The answered E-mails will not be considered as documents for proving certain items, since they are answered only to assist the teams regarding interpreting the rules.

At the site of SAE Brasil ([www.saebrasil.org.br](http://www.saebrasil.org.br)) there is an FAQ (Frequently Asked Questions) page, expressing the most common and important questions regarding AeroDesign 2008, so that all of the teams that might share the same doubts can find answers more quickly. Establishing this *FAQ Section* depends on the number and scope of the questions sent. Very specific questions or those that deal with confidential content (as requested by the team) will not be included on the FAQ page

- 6) It is very important to point out that the AeroDesign Competition is organized by volunteers and engineers active in the aeronautics field, who know the educational value of this type of initiative. Any attitude of the team, professor or school that is understood by the Organization as being contrary to this philosophy will be “pulled out by the roots”, even if provided for in the regulations or having precedent. The educational purpose transcends the regulations and it is impossible to provide for all of the ways they could be disrespected.  
It is always good to remember that for an SAE AeroDesign Competition to be successful and meet all of its objectives, the participation and collaboration of everyone is of fundamental importance.
- 7) The judges and inspectors are the main measuring instruments used to evaluate any one of the parts of the Competition. Their criteria and their eyes are the official measurements, and no decision they make will be revoked, even if an error of judgment is proven with film, etc.. It is impossible for the organizers to make precise technological resources available (for example, to precisely determine, to the “millimeter”, if the airplane exceeded the takeoff limit, or even to establish a single means of evaluating the Reports, since certain aspects, like logical organization or quality, depend on the experience, practice, and expectations of each one.
- 8) The Technical Committee encourages communication among the teams by:
  - Participating in the **3<sup>rd</sup> SAE AeroDesign Forum**, to possibly be held in April 2008. The date depends on location availability.
  - Exchanging experiences about the international Competition
  - Recommended reading
  - Consulting libraries of other schools
  - Loaning equipment and test sites
  - Internet sites: there are several very good sites on the subject
  - Photographic display
  - Exchanging test results of engines and propellers
  - Purchasing imported materials together
  - Exchanging descriptive materials regarding equipment
  - Conversations and discussions among the teams during the project or at the Competition
  - Others

However, the sharing of Reports and plans by one team with another (even from the same school) is not recommended, because discovery of the necessary analyses, solutions for relevant problems, and conclusions regarding important relationships between project aspects are the key to a good project and to the learning process.

9) Documents issued by SAE BRASIL for the Competition:

- ❑ **Regulations for SAE AeroDesign 2008:** Primary source of the technical requirements of the airplane and the Competition. This is mandatory.
- ❑ **Operational Procedures – SAE AeroDesign 2008:** Describes all of the technical and operational procedures to be followed for the 2008 Competition. It is the desire of the Technical Committee that the first version of the document be issued by mid-March 2008.
- ❑ **Safety Regulations and Good Practices – SAE AeroDesign 2008:** This document was first issued in 2006. For the 10<sup>th</sup> Competition (2008), besides revising and complementing the current document, the Technical Committee plans to divide it into two parts composed of mandatory items (“Regulations”) and recommended items (“Good Practices”). The purpose of this document is to assist the teams with the items that most affect, either directly or indirectly, the safety of the aircraft. The document not only assists the teams, but also the safety inspectors. A copy of the safety checklist will be attached to this document, as well as additional explanations regarding the items of the checklist, for the purpose of facilitating and improving the Safety Inspection process during the Competition, thus guaranteeing a better flow for the Flight Competition rounds and safer aircraft.
- ❑ **Minimum Project and Test Requirements (MPTR) – SAE AeroDesign 2008:** Primarily focused on the aircraft in the Open Class, for the purpose of establishing the necessary minimum aspects (or requirements) for the project of an aircraft in this Class. These requirements have existed since 2006 and will be revised and updated for this Tenth Edition of SAE AeroDesign 2008. See Section 3.7.8., page 37.
- ❑ **Registration Form:** The official registration form for entering the Competition. This is mandatory.
- ❑ **Preparing Reports:** Tips for preparing Reports. This is Informative.
- ❑ **Messages and Bulletins:** General information regarding the Competition, organization, parallel events, registration, and others. They can be either mandatory or informative. The informative bulletins and messages are published on the site of SAE BRASIL, and are numbered progressively, as they are released. In the case of conflicting information, the most recent is valid.
- ❑ **Procedures and Conduct Manual:** This may be issued up to a week before the Competition. The document consists of all of the procedures, structure and logistics of the Competition. This is mandatory and informative.

In the case of an eventual conflict between the documents above, the organizers must be advised and consulted. **Deliberately interpreting the information for convenience sake constitutes an entirely unacceptable attitude and could compromise the positive progress of the Competition.**

**Attention:** We recommend that all the teams, even before the release of the documents described above, regarding this year’s Competition (in this case, 2008), look for the

equivalent documents at the AeroDesign Competition site, at the link of the previous year (Ex.: SAE AeroDesign 2007).

Some of these documents will be based on the models of the previous year and could differ relatively little from the updates. Ex.: For the Open Class, the document Minimum Project and Test Requirements (MPTR) SAE AeroDesign 2007 is valid until its updated version is published on the site.

- 10)** All of the resources and infrastructure that SAE BRASIL offers during the Competition, such as electricity, work tables, parking, meals, kits (materials like T-shirts, caps, envelopes, sponsor kits, and others), multimedia projector, sound system and loudspeakers are furnished to provide more convenience during the Competition, but they come with no commitment of any kind, and do not signify any right to having them, even if some of the teams have used those resources or not. Therefore, no complaints will be accepted if any resource is broken, in poor working order, or has any other type of problem.

The only resources that SAE BRASIL assumes responsibility to provide, and that the lack thereof, or problems therewith, will not jeopardize the team are:

- ✓ Fuel for the Regular Class of the Competition (IMPORTANT: the fuel is only furnished for the official Competition rounds. The fuel will not be furnished for breaking in the engines or for flights that belong to the official Competition rounds). For the Open Class, the team is responsible for the special fuel (according to the first paragraph of item 3.6 of the Regulations). The organizers will only furnish fuel with 10% nitro methane.
- ✓ Computer & Data show / Overhead projector for oral presentations. We recommend bringing some form of presentation backup (transparencies, for example) in case there is any failure of the hardware or software, moments before the presentation.

## 5. Tips

We recommend that the teams extensively use checklists, like, for example, the technical aspects of the regulations, important dates, documents to send and deliver, etc....

Checklists normally help to not forget items on the correct dates, such as, for example, the pilot's license (from an Official Agency), in advance.

### 5.1. Important documents

Document	Delivery deadline
Proof of payment of the registration fee, and the registration form	At the time of registration
Five (5) bound copies of the Report, plans, and graph (do not forget the copy of the Liability Release bound with the Report) + CD with an electronic copy of the Report (see Section 5.1.1, page 55).	Final deadline, for sending without penalty:  <b>July 21, 2008 (Monday)</b>
<b>Additional Plans</b> and documents required in Sections 2.7.5, 3.7.9 (Propellers) and 3.2 (when applicable).	Final deadline, for sending with penalty: August 12, 2008.
Document proving matriculation for the first semester (or second semester*) of 2008.	September 12, 2008 (only for international teams).
<u>Brazilian teams*</u>	<u>Brazilian teams:</u> August 12, 2008
Liability Release (The lack of this document could cause a penalty)	At the time of registration With each copy of the Report
Declaration that the airplane has already flown	At the reception desk of the Competition (by noon on October 15, 2008)
Statement of agreement with the "Operational Procedures" and "Procedures and Conduct" (*)	At the reception desk of the Competition (by noon on October 15, 2008)
Copy of ABA membership card, or similar, for the international teams.	At the reception desk of the Competition (by noon on October 15, 2008)
Inform the radio frequency.	Right after registering (SAE will contact the teams)
Pilot change form (and for the SAE pilot)	At the reception desk of the Competition (by noon on October 15, 2008)

\* : The document "Procedures and Conduct", if issued, will come out no later than one week before the Competition, and must be written in the same form as the one issued in 2005. In 2006 and 2007, this document was not released.

## 5.2. Important Dates

Document	Delivery deadline
Registration	April 2008 (exact date yet to be decided)
Delivery of proof of matriculation (see above)	August 12, 2008 (Brazilian Teams) September 12, 2008 (International Teams)
Authorization to reuse the airplane (or part of the airplane not modified from 2007)	Two (2) months before the deadline for delivering the Report – May 26, 2008
<b>Send Report (5 copies + CD)</b>	<b>July 21, 2008</b>
<u>Deadline for sending the flight video:</u> Regular Class (Bonus - 5 points)	<b>September 29, 2008</b>
Open Class (mandatory)	<b>September 29, 2008</b>
Advise if needing the SAE pilot	No later than 10 days before the Competition: October 6, 2008
Communication regarding project changes <sup>(1)</sup>	No later than 10 days before the Competition: October 6, 2008
Receiving the Teams	<b>October 15 and 16, 2008</b>
Oral presentations <sup>(2)</sup>	<b>October 16, 2008</b>
Flight Competition <sup>(3)</sup>	<b>October 17, 18 and 19, 2008</b>
Publication of the official score	No later than 10 days after the close of the Competition.

- Note:**
1. Project changes not communicated are subject to more serious penalties, compared to those that have been previously communicated.
  2. The date of the 2008 Competition was put off two weeks later than previous years.
  3. In all, there will be three (3) days of flying, as in 2007 (Oct. 17, 18 and 19, 2008).

## 6. Role of the Faculty Adviser\*

The objectives of the AeroDesign Project are closely aligned with modern pedagogical concepts and with the MEC guidelines for university courses.

We recommend reading the following text: “The Role of the Adviser at AeroDesign”, because it gives tips on how the Adviser should proceed, enriching the AeroDesign experience for the students.

---

### *The Role of the Faculty Adviser at AeroDesign*

## **SAE BRASIL – AeroDesign 2008**

*“For the things we have to learn before we can do, we learn by doing” (Aristotle)*

This document focuses on the role of the Faculty Adviser of AeroDesign team.

The term “project”, cited in this document, takes in: conception, project, construction, tests, Report preparation, seeking sponsorship, team coordination, and all of the activities related to the work of the team for the AeroDesign Competition. All of these activities are directly related to the Competition and are a part of its challenge and educational role. Therefore, they should be performed exclusively by the student team, and not by academic advisers, professors, former students, school technicians, outsiders, professionals, and others.

We could say that selecting the number of participants per team, as well as the most appropriate profile those participants should have, in light of the activities to be carried out, should also be the exclusive domain of the team, itself. It is not a good idea that the members of the team be chosen by a third party like, for example, the coordinator of the course or the Faculty Adviser. This is a decision that only the team should make, based on the specific conditions of the participants and of the team, itself. A part of the learning process is to make inferences regarding the choices made and handle adverse interpersonal situations.

Learning should be one of the primary goals of each project destined for the Competition. The development of a project of this nature is a significantly realistic experience where future engineers, via field work in the area of Aeronautical Engineering, will have an opportunity, within a specific, multidisciplinary and focused time period, to develop a project that includes the various technical and interpersonal aspects common to the day-to-day activities of the industry.

The students are challenged to use their creativity, skills, capacities, imagination, and knowledge on this project. Teamwork is a very positive part of the project for the students, mainly for those who usually feel more inhibited in their creative and entrepreneurial abilities.

One of the objectives of the project is to stimulate the students to think and formulate their own questions. One of the biggest roles of the Faculty Adviser is to assist the students to develop confidence in seeking the best answers via research, so that they make their own choices and know why they arrived at certain conclusions.

---

\* We highly recommend that this item be read by the Faculty Adviser of the Team.

Above all, the Faculty Adviser should guide the search for the answer, instead of producing the answer himself.

It is also the Adviser's job to "develop the students" capacity to present their ideas, even if they sound absurd or take a direction that is potentially not the best.

The Adviser, therefore, should help to guarantee:

- ✓ The prohibition of people with exceptional skills for the Competition who, for some reason, are not eligible to be a member of the team. For example: a professional model airplane builder who is not matriculated as a student of the educational institution and, therefore, is ineligible to participate on the team.
- ✓ That the project be conceived, designed, and constructed only by the students, without the involvement of experienced engineers, aeronautical engineers, or any other related professional.
- ✓ That any knowledge or information furnished by professionals or Academic Advisers be treated as an alternative to be discussed. These professionals cannot (and should not) take part in the project or work decisions. *"It is doubt that provokes thought, and not confidence in having the answer."*
- ✓ That the construction tasks be carried out by the students. The "manufacturing" experience (and the planning for manufacturing) should also be a part of the preparation of an engineer.

As an educator, the Adviser should be concerned more about guaranteeing the educational aspects of the Competition proposed by SAE than about merely taking first place for the school.

The Competition does not have as its objective, neither does it encourage in any way, a dispute for superiority between schools and regions. The Competition's only objective is educational, by encouraging interest and providing for the spread and exchange of aeronautical engineering techniques and knowledge through a unique opportunity for developing the technical and personal capacities of the students to take on the labor market with much better preparation.

It is important to respond to the students regarding the project developed, thus providing due recognition for their work.

It is also the Adviser's job to keep the team united and always focused on the final objective. Therefore, knowing the members is a good way to recognize the weak points or conflicts of the group and to set up strategies for eliminating them. Maintaining high morale, even when the problem seems unsolvable, should be a constant attitude of the Adviser.

The Adviser plays an extremely important role during and after the Competition, stirring reflection on what went right and wrong in the project, calling for critical evaluations of the project, in comparison with the others (including the organizational and behavioral aspects of the team), making the students evaluate where they got it right and where they got it wrong.

Later, we will see that the objectives and purposes of the AeroDesign Project coincide with modern pedagogical concepts and also with MEC (Ministry of Education and Culture) guidelines for undergraduate courses, in general, and engineering, in particular.



## **Pedagogical Techniques**

**“The main objective of education is to create people who are able to do new things, not only to repeat what other generations did – people who create, invent and discover. The second objective of education is to form minds that can be critical, verify, and not accept everything that is presented to them. The biggest danger, today, comes from the slogans, collective opinions, ready-made thinking trends. We have to be able to resist, individually, by critiquing, distinguishing between what is proven and what is not. Therefore, we need to be active disciples who learn, early, to find things on their own, partly, via their spontaneous activity and, partly, by the material we prepare for them; who learn, early, to say what is verifiable and what is merely the first idea that came to mind.”**

(Jean Piaget)

The constructivist approach is rooted in the genetic epistemology of Jean Piaget, and constitutes constructing knowledge via experiments and life experience. It seeks to explain how an individual learns, gains knowledge and develops intelligence. Psychogenetic theory says that this building of knowledge will only be accomplished if the environment provides imbalance.

We can say that when an organism changes its behavior as a consequence of its experience, learning has happened.

The active participation of the students presents many more advantages than passive participation. In a constructivist approach, the students learn through reflection and understanding, seeking answers, and in interaction with the world. Creativity is developed, because creation involves thinking.

In order to achieve the quality of experience demanded for maximum development of intellectual potential, reflection is also needed. Instead of receiving a set of facts and generalizations from the professor, the students are confronted with a problem - unclear or enigmatic. This level of learning requires more active participation, a more critical attitude regarding conventional thinking, more imagination and creativity.

The relationship of the professor with the student is decisive for the learning process to be successful. As a rule, there are three types of professor-student relationships: authoritarian, *laissez-faire*, and democratic. The last characterizes the constructivism that has become best known and most efficient. Professors are democratic group leaders. Their main objective is to lead the students to study significant problems in the professor's discipline or area. That type of study presupposes an exchange of evidence and insights, interchange, and respect for the ideas of others.

In a democratic classroom, the ideas of the professor and of the students are equally subject to criticism, by both the professor and the students. In this way, both the students and the professor learn together. Although professors might be experts in their areas (capable of teaching it in the best possible way), the situation is prepared so as to encourage the students to think for themselves. According to this process, a democratic professor will probably adopt a learning approach that emphasizes the international scope of human experience and behavior.

There is nothing in the world, in any area of human knowledge that is finished and ready. Knowledge cannot be communicated to another as merely something irrefutable and final.

In this approach, the individual and the environment are of equal importance in the process of building knowledge. The professor directs the learning, and the student

actively participates in the learning, itself, by experimenting, doing group research, stimulating doubt, developing rational thinking, and other procedures. The professor is a guide, a learning facilitator, and creates stimulating and answer-motivating situations, and must have the skill for guiding and helping. The object is to facilitate the use of cognitive behavior by the student, which we commonly call rational thinking.

**The presentation of ready-made knowledge is rejected, because the person learns better when directly taking part in constructing the knowledge acquired. This is “learning by doing”.**

From this perspective, error is a necessary factor for achieving learning.

With this approach, interdisciplinary, multidisciplinary and cross-disciplinary work is recommended, because “one does not learn in small pieces, but rather by immersing in a set of problems that evolve various concepts ant the same time.” <sup>(1)</sup>

The result of all this is self-sufficiency in searching for answers, intellectual autonomy, and the pleasure of learning, and students become thinking beings who can develop on their own. The learning effort is substituted by interest.

*“We do not learn linearly, by calmly and serenely adding a few more elements than we previously knew. We learn while permeated with great periods of conflict, break-ups. This experience is painful and we flee from it, but it is the heart of Post-Piaget Constructivism.”* <sup>(2)</sup>

Encouraging the educational role of professors and Advisers is fundamental for them to be aware of the function they are to fulfill, which is to form more complete students, technically and humanly speaking, and to do this, they must step back from focusing on their pet projects and ideas, in order to allow these students to develop.

## **MEC Guidelines**

(Taken from the site <http://www.mec.gov.br>)

*“We also believe that the realities of the 21<sup>st</sup> century require that all of us adopt the newest methods and the most modern technologies in our pursuit of truly global modernization in the educational area, so that all achieve excellence.”*

(MEC, Conclusions of the meeting of the Ministers of Education and Representatives of the E-9 member countries in Recife, Pernambuco, Brazil, from 1/31/00 to 2/2/00).

### **Higher education courses - principles**

- Give incentive to a solid general formation, which is necessary for the future graduate to be able to overcome the challenges of renewed professional working conditions and of producing knowledge, allowing a variety of types of formation and different skills in the same program;
- Stimulate independent study practices, for the purpose of the student’s progressive professional and intellectual autonomy.

---

(1) In *Nova Escola*, March/95

(2) In Grossi, E. P., Bordin, J. “Post-Piaget Constructivism – a new learning paradigm” Ed. Vozes, 2. Ed., Petrópolis, 1993

- Encourage using the acquired knowledge, skills and competence outside of the school environment, including those referring to the professional experience that is considered to be relevant for the area of study under consideration.
- Strengthen the presentation of theory with practice, valuing individual and collective research, as well as stages and participation in extension activities, which may be included as part of the course load.

### **Curriculum guidelines for engineering courses**

**Art. 1** - The Curricula of Engineering Courses must provide conditions for their students to acquire a professional profile which includes a solid technical-scientific and general professional formation that enables them to absorb and develop new technologies, stimulating their critical and creative involvement in identifying and solving problems, considering their political, economic, social, environmental and cultural aspects, with an ethical and humanistic vision of meeting the demands of society.

**Special Clause** – It is part of the profile of the graduates from an Engineering Course, guaranteed by its Curriculum, to constantly keep professionally updated.

**Art. 2** - The Curricula of Engineering Courses must provide conditions for their students to acquire competence and skills for:

- a) Applying mathematic, scientific, technological, and instrumental knowledge to engineering;
- b) Projecting and conducting experiments and interpreting results;
- c) Conceiving, projecting and analyzing systems, products and processes;
- d) Planning, supervising, preparing, and coordinating engineering projects and services;
- e) Identifying, formulating and solving engineering problems;
- f) Developing and/or using new tools and techniques;
- g) Supervising the operation and maintenance of systems;
- h) Critically evaluating orders of magnitude and the significance of numerical results;
- i) Communicating efficiently in writing, orally and graphically;
- j) Acting on multidisciplinary teams;
- k) Understanding and applying professional ethics and responsibility;
- l) Evaluating the impact of engineering activities on the social and environmental context;
- m) Evaluating the economic feasibility of engineering projects.

## CHAPTER II

### PEDAGOGICAL PROJECTS

**Art. 3** – Each Engineering course should have a pedagogical project that clearly demonstrates how the set of activities carried out will guarantee the desired profile of their graduates and the development of the expected competences and skills.

**Art. 4** – The curricular structures must be organized so as to allow sufficient time for consolidating the knowledge acquired and for complementary activities, for the purpose of the student's progressive intellectual autonomy.

**Special Clause** – The need is emphasized for reducing classroom time and favoring individual and group work for the students. The time dedicated to these activities may not be counted in the course load.

**Art. 5** – There must be work that synthesizes and integrates the knowledge acquired throughout the course. At least one of them must be a mandatory activity which is required for graduation.

**Art. 6** – Complementary activities must be stimulated, such as initial scientific work, multidisciplinary projects, technical visits, teamwork, prototype development, monitoring, participation in junior companies, and other entrepreneurial activities. These activities seek to develop cooperation, communication and leadership stances.

# PART II

# **10<sup>th</sup> Competition**

## ***SAE BRASIL AeroDesign***

***Regular and Open Classes***

### ***Competition Regulations: COMMENTS***

Additional comments **highlighted in yellow**

## INTRODUCTION

The AeroDesign Project, organized by SAE BRASIL (Sociedade dos Engenheiros da Mobilidade), consists of an engineering Competition open to undergraduate and graduate university students in Engineering, Physics and Aeronautical Sciences.

By organizing and holding this Competition, SAE BRASIL is accomplishing one of its missions, which is to contribute to the academic formation of future mobility professionals.

The Competition offers a unique opportunity to undergraduate and graduate students, organized into teams, to develop an aeronautical project in all of its phases, from its conception, through detailing the project, building and testing, to actually running trials on it in conjunction with other correlated projects.

In this manner, the students are also stimulated to develop abilities that will play an important role in their future careers: leadership, team spirit, planning, and the capacity to sell projects and ideas.

SAE BRASIL AeroDesign Competition has the institutional support of the Ministry of Education and Culture (MEC), because it is in line with and meets the objectives of the Ministry's policies and guidelines (Item 6, above).

The Competition has been held in the United States since 1986, where it was conceived and held by SAE International, which founded SAE BRASIL, in 1991, and with which the latter is affiliated. Under the name of SAE AeroDesign, the Competition involves representative schools from the U.S.A. and several countries from Europe and the Americas.

In 1999, this Competition began to appear on the calendar of student events of SAE BRASIL.

The two winning teams of the Brazilian edition of the Competition, in the Regular Class, and the first place in the Open Class earn the right to participate in a similar Competition promoted by SAE International, during the first semester of the following year. They compete with teams from different countries and, for this purpose, have the technical, logistical, and financial support of SAE BRASIL.

With the objective of competing in the 2008 edition of the SAE BRASIL AeroDesign Competition, each competing team should design, document, build, and fly a radio-controlled airplane to lift the biggest possible "useful load" (lead or steel bars), according to specific norms established in advance for each class.

A series of aspects should be noted, in order to guarantee the success of the project:

- Preliminary Project
- Calculations
- Tests
- Project Details
- Construction
- Report Preparation
- Oral Presentation
- Flight Competition

Besides the technical requirements, the team must concern itself with a variety of other aspects in order to achieve the success of the project:

- Seek sponsorship (financial support)
- Planning
- Effective leadership
- Teamwork
- Logistics
- Communication skills
- Interpreting the rules
- Creativity and Innovation
- Having a sporting spirit

All of these aspects are part of the challenge, and practicing them during the a university course complements the technical aspects that are learned in the classroom or from books. The projects are judged according to a variety of areas. The total score takes in the following items:

- Project Report (containing plans and expected “useful load”)
- Oral Presentation
- Maximum Weight Carried
- Accuracy of Estimating the Weight Carried
- Design – Construction consistency
- Bonuses and penalties

All of the information found in these regulations are **MANDATORY IN NATURE**.

As was explained in the first part of this document (page III, above), the parts **highlighted in yellow** are information that is complementary to the Regulations with the objective of clarifying several aspects of the Regulations, in order to furnish a single correct interpretation of the text, by using examples, details and additional figures. These items also enumerate some of the main important aspects regarding the Competition that were brought together in a single document, in order to avoid redundancy and doubts and to facilitate finding the information.

The information regarding operational procedures to be followed during the 10<sup>th</sup> SAE AeroDesign Competition will be explained in detail in the specific document: **Operational Procedures – SAE AeroDesign 2008**.

It is extremely important that all of the team members carefully read the document cited above, because it explains how the Competition works in all of its aspects. By being profoundly familiar with all of these procedures, all of the participants – judges, inspectors and team members – can collaborate so that a greater number of Competition rounds are achieved and, thus, an even more successful Competition.

**We repeat: the success of the Competition depends on EVERYONE.**



The changes or most relevant items of the AeroDesign 2008 Regulations, in relation to the previous Regulations, applicable to the 2007 Competition, are:

**Regular Class**

- New dimension restrictions (see Section 2.2.1, page 15).
- Introduction of an evaluation of construction quality. (see Section 2.2.3, page 18).
- Cargo compartment should have minimum standard dimensions of 110 x 160 x 350 millimeters (4.33 x 6.30 x 13.78 inches). (see Section 2.5, pages 19 and 20).
- Introduction of the “segmented runway concept” for takeoffs. Two Sections: 30.5 meters (100 feet) and 61 meters (200 feet). (see Section 2.8, pages 26 and 27).
- Additional points (bonus) for maximum payload/empty weight ratio (or EE factor) defined by a new exponential equation (see Section 2.9.3, pages 28). The bonus is based on the final Report grades.
- The bonus for the minimum volume of the box (i.e., rectangular prism shape) able to hold the disassembled aircraft was increased to 15 points and the equation that establishes this score was modified. Bonus valid only for the 30 smallest boxes. We ask for an additional drawing of the aircraft showing how its parts will be allocated inside the box (see Section 2.9.5, pages 29 and 30). This drawing should be bound with the Report.
- The bonus for the Flight Video was increased by 5 points.
- Specific safety requirements (see Section 2.7, pages 22 to 26).

**Open Class:**

- Only teams with at least three students that are veterans of AeroDesign (students with a history of at least one complete participation in AeroDesign in the Regular or Open Class) are eligible. See Section 3.1., page 31.

The schools or teams that do not totally conform with the item, above, that is, that do not have a history of previous complete participations, will only be eligible to participate in the Regular Class (See Section 3.1., page 31).

- Minimum battery charge continues to be 1000 mAh for each receiver used (see Section 3.7.2.2, page 34).
- A PCM Radio System is mandatory for the Open Class.
- Specific safety requirements (see Sections 3.7.1 to 3.7.13).
- Improved “Follow-up and Validation Process” (see Section 3.7.8, page 38) and specific Technical Bulletins to be released early in 2008).

This process seeks to guarantee that the minimum project, construction, and test requirements to be established by the Technical Committee are achieved, thus contributing to greater aircraft safety, besides a greater learning experience and better professional preparation of the students involved in the entire project.

- Bonus for empty flight increased to ten points. (Section 3.9.4, page 41).

**Open and Regular Classes:**

- New bonus for a valid landing on the runway. For 2008, this bonus is a function of the Payload and the Empty Weight of the Aircraft. (See Section 4.1.6., page 45)
- The score for the Design Competition (Report + Oral Presentation) continues to be 200 points (165 points for the Report and 35 points for the Oral Presentation).

## **1. Shared Requirements – Open and Regular Classes**

### **1.1. Objective and Scope**

The SAE BRASIL AeroDesign Competition is open to undergraduate students in Engineering, Physics or Aeronautical Sciences who must conceive, design, build and test a radio-controlled model airplane. The 2008 edition of the Competition provides for **REGULAR** and **OPEN** classes.

**Note 1:**

For the Open Class, only: besides undergraduate students, Master's and Doctoral students may also participate (*stricto sensu*) in the areas mentioned above. See Chapter 3.

**Note 2:**

The teams formed to compete during AeroDesign 2008 may include students of *Industrial Design (or Product Design)*, as long as at least 80% of the team (or 4/5) are engineering students.

### **1.2. Project Objective**

The team must design and build an original radio-controlled airplane that meets the requirements and restrictions established in these Regulations and is able to carry the heaviest possible payload. Some of the additional challenges are being accurate in predicting the payload that the airplane will be able to carry, the structural efficiency factor, and the minimum volume of the disassembled aircraft. For 2008, and exclusively for the Regular Class, the takeoff requirements (or maximum runway length) were established so that the points per weight carried are a function of the takeoff distance. For each takeoff Section (30.5 meters (100 feet) or 61 meters (200 feet)) points will be awarded per weight carried (see item 2.8, page 26).

### **1.3. Competition organization**

The Competition is divided into two parts: 1. Design Competition and 2. Flight Competition:

- 1. Design Competition** – the teams will present their projects and will demonstrate their calculations for determining the maximum payload that the airplane can carry, as well as the various criteria used to define the aircraft. In this context, “project” is understood to be the thinking, duly justified, used to conceive the aircraft proposal developed by the team to participate in the Competition.
- 2. Flight Competition** – establishes the maximum payload that each airplane can carry. The precision of the project (or calculations) is taken into account in the results, by comparing the estimated payload with that which was actually transported in flight.

**Although the competitions for the Regular and Open classes are held simultaneously, the evaluation of each of the classes will be done separately.**

## 1.4. Outside help

With the objective of assuring the credibility of the SAE BRASIL AeroDesign Competition and preserving its educational purposes, the professor responsible for each team should prohibit, during all of the project and construction phases, the help and/or participation of people who have broad knowledge and experience regarding the Competition (ex.: a professional model builder) and whose contribution could decisively unbalance the equality between the competing teams.

Therefore, the professor who is responsible must make a signed statement to this effect, which is included in Appendix 6.6, page 81.

The airplane should be conceived, designed and constructed by the students without the direct involvement of professional engineers, builders of radio-controlled models, operators specializing in tools, pilots or related professionals. The students may use any literature or related knowledge in designing and building airplanes or radio-controlled model planes, as well as information from professionals or professors, as long as they are offered in discussions of alternatives with their pros and cons and are mentioned in the references of the project Report. However, the professionals may not participate in the project decisions or contribute to the drawings, Reports or building the airplanes.

The item, Role of the Adviser, in this document (Part I, item 6, above), clarifies some of the basic points of the educational role of this Competition. The Competitions promoted by SAE BRASIL are not held for the purpose of ranking universities, cities, states or regions. Merely participating in the Competition provides numerous benefits to the students and is considered to be a true demonstration of their entrepreneurial ability.

At the present time, the Technical Committee of AeroDesign is formed entirely by engineers who participated in the first editions of AeroDesign in Brazil and now are involved in the aeronautics industry. For this reason, we are convinced, by our own experience, of the importance of having the participation of a broad range of students in ALL the phases of the work. AeroDesign provides theoretical and practical experience that, when well-used by the student, results in a solid contribution to the formation of a more complete and multidisciplinary professional.

## 1.5. Pilot requirements

Although the project and building of the aircraft must be authored by the students who are on each team, the pilot does not need to be a member of the team or even be associated with SAE BRASIL. Nevertheless, it is necessary that the pilot be experienced and certified by an official Federation or Academy of Model Aeronautics (ex.: AMA – Academy of Model Aeronautics).

For those cases where the team has no pilot at the time of the Competition, the Technical Committee may make a substitute available, as provided in Appendix 6.8, page 83.

**SAE BRASIL reminds every team that the pilot's license is renewed yearly and should be provided for in advance.**

### **Forms to fill out, in Appendix 6.8:**

(Liability Release for Changing the Pilot) page 83.

When a team wishes to use a pilot from SAE BRASIL, it must communicate this to the organization, via E-mail, at least one week before the beginning of the Competition. The form must be filled out and delivered at the reception desk of the

event, leaving the name of the Previous Pilot blank, and filling in Substitute Pilot as "SAE BRASIL Pilot".

Any eventual change of pilot before or during the Competition should be communicated by filling out the form and delivering it to the Technical Committee.

For the international teams, the official membership card of the country of origin (ex.: AMA – Academy of Model Aeronautics, or similar) may be accepted. However, additional procedures for the participation of foreign pilots may be required. The teams will be notified of these procedures in good time.

## 1.6. Registration Fee

The registration fee must be sent to SAE BRASIL by the deadline, as in Appendix 6.7, together with the Registration Form and Liability Release (Appendix 6.6). The registration fee will not be refunded under any circumstances. It is the responsibility of the team to see that the payment of the fee has been received, in order to guarantee its registration.

The Registration Form is available at SAE Brazil's Internet site: [www.saebrasil.org.br](http://www.saebrasil.org.br)

## 1.7. Entering several airplanes from the same educational institution

More than one team from the same higher educational institution may participate in the Competition, as long as the following restrictions are complied with:

- For every airplane registered, there must be a specific team.
- Each airplane registered must be visibly distinctive in its dimensions and geometric shapes.
- The teams may eventually work together, but their project philosophies must be distinct from each other.
- The registered airplanes must show clear design differences from each other. It is understood that different projects follow distinct lines of thinking in defining each airplane.
- Each student may register with only one team.

Each airplane should clearly represent a single project. In the case that, in the opinion of the organizers and judges, two airplanes are not characterized as significantly different, the registration will be considered as only one and, that being the case, only one aircraft may remain in the Competition.

The choice of the aircraft that will remain must be made by the teams involved in the occurrence. The responsibility for this choice is not up to any judge or inspector.

**Attention:** This communication may occur even during the Flight Competition.

For the present time, the number of teams per University (or Institution) will not be limited, but after receiving all of the registrations, if it is necessary to reduce the number of teams because of space and time limitations<sup>(1)</sup>, the Universities will be informed.

In this case, the schools will be allowed to merge the members of the registered teams and the registration fee will be duly refunded.

(1): Time to guarantee an adequate number of rounds for the flight competition.

The Organizing Committee SUGGESTS, because of the growing number of teams every year, that each University register no more than four teams per year in the Competition.

Special cases could perhaps be accepted, but via an evaluation. Example: if the number of students should be too large, in order for them to be distributed in four teams, the school could come with one more team. **No more than five teams will be accepted per institution!**

We recommend that the teams be formed by groups of no more than 10 to 15 students, except for special cases or where the option is to have one larger team, in stead of two.

Increasing the number of teams from the same school (or University) in each Competition should be done as consistently as possible by that educational institution. This is very important for guaranteeing full participation by all of the students involved, as well as for ensuring the good progress of the Competition.

Carefully and appropriately establishing the number of teams from each school for the same Competition is considered by the Technical Committee to be an essential contribution from those institutions to the good and successful progress of the Competition.

## 1.8. Airplane configuration

### 1.8.1. Airplane type and restrictions (Open and Regular Classes)

Only fixed-wing aircraft are allowed to compete. It is prohibited for any aircraft to participate that:

- Functions by floating with lighter-than-air gases (for example, dirigibles and balloons), or that uses gases that have less density than air that make any type of contribution to lift<sup>(2)</sup>.
- Produces lift with rotating wings (for example, helicopters, auto gyros and gyrocopters)<sup>(2)</sup>.
- Has another type of additional or auxiliary propulsion. The only means of propulsion of the airplane should be via a standard engine.
- Uses auxiliary devices for takeoff that do not pertain to the airplane (including human assistance) and that are not connected physically to the airplane when it lands.
- Has sharp tips or edges that could cause serious injury in the case of an accident (example: winglets or endplates made of metal sheeting or with sharp and/or cutting tips).

**It is not prohibited to use wing tip surfaces (winglets or endplates) if proper care has been taken so that they do not present sharp and/or pointed tips.** Ex.: if the team decides to use triangular endplates made of sheeting, the exposed tips of the triangle cannot be sharp (pointed) in other words, they should be rounded. This sheeting also cannot have jagged edges resulting from the cutting process.

(2) : Dirigibles, lighter-than-air, gyrocopters or helicopters are not permitted, although they are welcome for showing their capabilities, during an *hors-concours* (noncompeting) demonstration, at a time and date to be negotiated with the Technical Committee.

### 1.8.2. Reusing the airplane

When an airplane has already participated in an SAE AeroDesign Competition in Brazil (by any team, whether from the same school or not), the use of the same aircraft, its structure or the same project are prohibited, unless substantial changes have been made and can be clearly shown.

These changes must be approved in advance by the Organizing Committee of the event and duly documented. Appropriate reference to the prior approval of the Organizing Committee, including the date, should be included in the Project Report.

The deadline for sending the documentation regarding the reuse of the airplane is one month before sending the Project Report. The approval request will be answered in no more than two weeks. **This documentation should be attached to the end of the Project Report. It is not considered to be a page of the Report, therefore, it should not be numbered.**

The documentation must be sent by E-mail, preferably in “pdf” format. “CAD” drawings will not be accepted. Include them in the descriptive document as a figure in Word. Do a virus check of the E-mail and the attached files. The contact E-mails have virus protection and, if the files are infected, they are not received. Please **DO NOT SEND E-MAILS WITH MORE THAN 2 Mb.**

Examples of projects that require approval:

- Airplanes with one or more parts that are **geometrically and aerodynamically** similar to those used in previous years.  
Ex.: an airplane in 2008 that has the same wings (platform and aerodynamic profile), or the same fuselage of another that has competed in previous years in the Brazilian Competition.  
**The Technical Committee not only suggests, but values the original work developed by the team that seeks to optimize its project.**
- Airplanes with no changes in basic design (ex.: wing area, aspect ratio) or that have merely been improved over airplanes used in previous Competitions.

Similar project philosophies do not require approval: Example: cargo compartment inside the wings, biplane, “H” tail, conventional, and others.

**The “painting” of the aircraft (or pattern of colors adopted by the team) obviously is not considered to be a technical similarity between two projects.**

Airplanes that have small differences from another airplane, used in a previous Brazilian Competition, will not be allowed (for example, the use of the same airplane as the previous year with the only difference being the horizontal tail plane).

The Project Report, as well as the plans and material for the oral presentation, should be different, that is, they cannot have the same format, same project rationale, or same tests used in previous Competitions. The Project Report must clearly show that it is a new project.

Texts (or paragraphs) that are very similar between the Reports of the current year and those of previous years will not be accepted and will be the basis for penalizing the project involved.

Any conclusions, even though brilliant, that have been presented in Reports of previous Brazilian Competitions will not necessarily be taken into consideration. The objective of the Committee, by introducing modifications in the Regulations, is that each project be new and unique, thus demanding original conclusions regarding the Regulations.

**If any plagiarism is found in any part of the Report, the final score will be HEAVILY penalized.**

The Technical Committee modifies the Regulations of the Competition every year, because it believes that part of the responsibility of guaranteeing that new projects be developed could and should be a function of the Regulations.

The Committee also feels that the teams formed to participate in AeroDesign should develop a brand-new project and that the entire work process should be reinitiated with the start of each new project.

For the team or members who participated in previous Competitions, it is acceptable that they learn from their mistakes and design an airplane with solutions for the problems experienced in previous Competitions, or even that they optimize some aspect (fuselage, for example) of the airplane used in a previous Competition. In these cases, it is REQUIRED and MANDATORY to have authorization for reusing the airplane.

If airplanes are found that do not qualify as new projects, and authorization has not been requested and approved, the team will be duly advised and may no longer receive authorization to participate in the Competition. This measure can occur even during the Competition.

Aircraft developed for the Competition in the United States (SAE AeroDesign East) are eligible to participate in Brazil only once, as long as they have not previously appeared in the Brazilian Competition and, logically, are in line with the Competition rules.

Since 2006, especially for the Regular Class, the SAE AeroDesign Brasil and USA Competitions are considered to be distinctly different challenges in terms of their rules and procedures and, in 2008, this will be extended to the two Classes (Regular and Open).

## **1.9. Modifications and Nonconformities – Loss of Points**

### **1.9.1. Project Modifications**

Modifications in the airplane must be presented to the Technical Committee, in writing, no more than 15 days before the beginning of the Competition. The judges will decide on points to be taken off, based on the magnitude of the changes made, in comparison with the project as described in the Report originally presented. Modifications made during the Competition – whether to improve/correct the project, or to resolve safety problems found during inspections – will only be permitted if previously approved by the judges on the Technical Committee, and they will be subject to penalties, if they imply nonconformity with the project. The decision of the judges regarding the modification cannot be questioned by the team.

Modifications that are not communicated and are not approved in advance will be penalized more severely. Ex.: structural modifications in aircraft in the Open or Regular Class without approval by the judges or the Technical Committee.

Project changes must be communicated by E-mail, preferable in “pdf” format. Do not send drawings in CAD format. Include them in the descriptive document as a figure in Word. **DO NOT SEND E-MAILS WITH MORE THAN 2 Mb.**

### 1.9.2. Nonconformity with the rules

Checking nonconformities with requirements for: 1 – cargo bay (including smaller dimensions of the cargo bay than what is specified), 2 – aircraft with larger dimensions than the maximum sizes set forth in item 2.2.1, and 3 – visible differences between aircraft and drawings, will suffer penalties that have not been preset, but that could even result in disqualifying the team.

## 1.10. Airplane identification

All aircraft must come with some form of clear identification, with the number of the team and with the name of the educational institution.

The correct identification of the aircraft is of extreme importance, because it aids and facilitates procedures during the Competition ensuring that it progresses well.

The identification of the airplane should be done, as follows:

### 1.10.1. Team number

The number of the team should be affixed on the aircraft in the following places:

- Upper surface of one of the wings.
- Both sides of the vertical stabilizer.
- Both sides of the fuselage (where it is most visible).
- If possible, on the underside of one of the wings.

The numbers marked on the wings of each airplane must be at least 10 cm high and in legible and indelible letters.

On the fuselage and on the vertical tail plane (stabilizer and rudder), these numbers may be proportional to the area on which they are affixed.

If the number is not visible, making rapid identification of the aircraft difficult, the team may be asked to provide this identification during the Competition. Not heeding this request could cause the team to be warned or a penalty could be established, as the case may be.

The number of the team is set according to the order in which the registrations are received.

If the configuration of the airplane does not allow the number to be placed as described above, the airplane must have the number of the team with the minimum specified size, so that the number appears when the airplane is being observed from above, the left and the right.

### 1.10.2. Name of the educational institution

The name of the educational institution (school and/or university) should be clearly shown in at least one of these places:

- on the wings;
- on the fuselage;
- on the vertical tail plane.

The initials of the educational institution can be used if they are unique and nationally recognized.

The identification of the educational institution does not exclude the need for identifying the team (number), as specified above.



## 1.11. Complaints, Protests and Suggestions

### 1.11.1. Complaints and Protests

Any complaints regarding errors in the score or other aspect of the Competition must be made in writing, and only by filling out the specific form to be supplied by the Technical Committee during the Competition. The complaints must be identified and signed by the captain of the team making the complaint. The forms must be delivered to a Committee member and will be duly considered by the Committee as soon as possible, during the Competition.

If they are pertinent, the Technical Committee will take the necessary actions with notification to the team making the complaint, as soon as possible, and no later than the following day. Complaints made on the last day of the Competition will be answered within a week after the Competition, before publishing the official score.

Complaints regarding the score released during the award ceremony must be sent to the Committee via E-mail no later than five (5) days after the Competition.

**The decision of the Technical Committee will be final and irrevocable. It will be given in writing and released during or after the Competition. Any arguments with the Committee or any of the judges and inspectors, after the decision has been made public, may result in losing 25 points or in the immediate disqualification of the members of the team from this Competition. Insisting on discussing decisions of the Technical Committee, that are based on the Regulations, that is, insistence in making exceptions to the Regulations, for any reason, may disqualify the team.**

**Any attitude on the part of the team (or member of the team) that is shown in an unsportsmanlike manner (ex.: extreme verbal aggression toward any person in the Competition environment) may result in the school being prohibited to participate in up to two subsequent Competitions.** AeroDesign no Brasil, since its first edition, has had a very favorable atmosphere of friendship and collaboration among all of the teams, volunteers, and collaborators, therefore, it is the responsibility of one and all to maintain this excellent environment.

**It is the obligation of any participant to inform the Technical Committee of the Competition (yellow shirts), or the coordinator of the security staff, regarding any issues related to security. If some aspect or characteristic is detected, whether of an aircraft or facilities, that compromises the safety of the flight or of those in attendance, this should be communicated immediately to the one in charge of security. All of the items pointed out will be evaluated exclusively by the Technical Committee and there is no place for discussions, afterwards, regarding the final decision of the Committee.**

### 1.11.2. Suggestions

A suggestion box<sup>(1)</sup> will be available at the places where the Competition takes place. The suggestions will be read only after the end of the Competition. Any suggestions regarding the rules will be taken into consideration for the Competition of the following year.

The Organizing Committee will also furnish a form on which each team (or team member) may evaluate the organization, the progress of the Competition, the layout of the area and other pertinent aspects. This evaluation will serve as the basis for future improvements.

The identification of the team (or of the team member) on the evaluation form IS NOT MANDATORY.

The primary objective for creating this evaluation document, and mainly the fact that it is not mandatory for those filling it out to identify themselves, is to know the TRUE OPINION of the participants regarding the items shown, above, as well as others.

We could say that the main mission of the Technical and Organizing Committee of AeroDesign is to prepare a Competition where the educational objectives, in all aspects, are fully achieved. To that end, the participation of everyone, by sending opinions, questions, suggestions, and evaluations, or even criticism, is of fundamental importance to fully achieving these objectives.

---

(1) Aside from the existence of the suggestion box, the Technical Committee strongly encourages all of the teams to fill out the form and/or any additional page with criticisms, suggestions, and/or complaints of any type. Please only turn in these documents to one of the members of the Technical Committee (yellow shirts) at the operational tent (tent at the hangar and the weighing scales). These observations or suggestions are very important for the continuous improvement of the Competition in all of its aspects. We repeat the collaboration of everyone is essential.

## 2. Requirements – Regular Class

### 2.1. Eligibility – Team members

The **REGULAR CLASS** is limited to undergraduate students in Engineering, Physics or Aeronautical Sciences, associated with SAE BRASIL.

Students who have graduated during the school semester immediately preceding the Competition ARE NOT eligible to participate. It is mandatory that the documentation regarding enrolment in 2008, be sent accordingly Sections 5.1 (page VIII) and 5.2 (Page IX) above.

All of the members of the team should be members of SAE BRASIL, and the membership card or other document that proves the membership could be required during the Competition. Information is available regarding this association at [www.saebrasil.org.br](http://www.saebrasil.org.br).

### 2.2. Geometric Restrictions (“Four-Dimensional Hangar”<sup>(1)</sup>)

#### 2.2.1. Basic Requirements

The aircraft in the Regular Class must be designed in such a way that, when they are completely assembled (and in the takeoff configuration<sup>(2)</sup>), the following maximum dimensional restriction is met.

$$L + H + \sum_{i=1}^n B_i = 6.35 \text{ meters} \quad (\text{or} = 250 \text{ inches})$$

Where:

“**L**” = the maximum length, or the maximum dimension found from the frontmost to the hindmost part of the aircraft. This measurement is taken parallel to the ground (or reference surface) and with the control surfaces at zero deflection (or that which results in the maximum length). See Appendix 6.4A, page 75, item i.

“**H**” = the maximum height, or the maximum distance found from the ground (or reference surface) to the highest point of the aircraft. This measurement MUST be taken when the aircraft is empty. The propeller will not be taken into consideration. See Appendix 6.4A, page 75, item ii.

“**B<sub>i</sub>**” = the maximum wing span (or maximum width) of each “Group of aerodynamic surfaces” that generate vertical lift, or have a vertical lift component. The term “group of aerodynamic surfaces” or “group of surfaces” will be explained, below.

“**n**” = the number of “group of aerodynamic surfaces”.

---

(1): An additional explanation of the name “Four-Dimensional Hangar” can be found in page 76.

(2): When we say that an aircraft must keep the same position that it will take upon takeoff, it is generally understood that the aircraft, when it is in the process of checking the dimensions, is 100% assembled, without cargo and cargo support, and is in a position similar to that of the beginning of the takeoff run.

**Definition of “group of aerodynamic surfaces”:** this is the name given to a set of aerodynamic surfaces where, in the case of multiplane<sup>(1)</sup> aircraft, each one must have a certain degree of overlap, viewed from above, with all others of the same group. If any surface does not overlap (even partially) all the others, this will be considered as an additional “group” (or surface) and its span will be calculated separately. See figures 1 and 2, below.

For example: for conventional monoplane aircraft, the wing is considered to be a group of surfaces and the horizontal tail plane as another group of surfaces, that is:  $L + H + B_1 + B_2 = 6.35$  meters. For more details and a few other examples, see Appendix 6.4B, page 77.

The overlap will always be checked by a section of the overlapped area on the “aircraft drawings” (plan and side view drawings) so that, even with the presence of dihedrals or sweepbacks, the rule will be applied. This check will be made on the drawings and by observing the aircraft, itself.

**Attention:** *it is important that an overlap occur along the entire span or most of it. Small wings, flaps or fake surfaces do not necessarily ensure the overlap.*

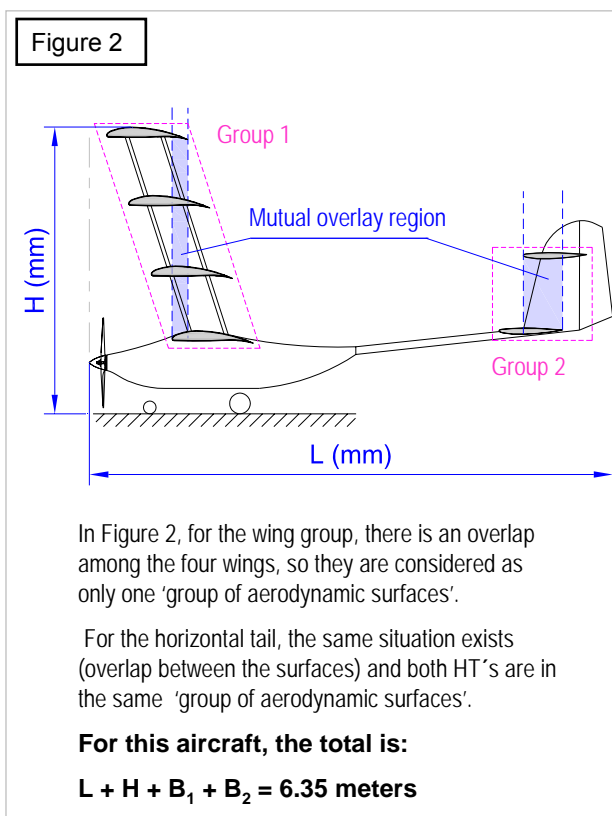
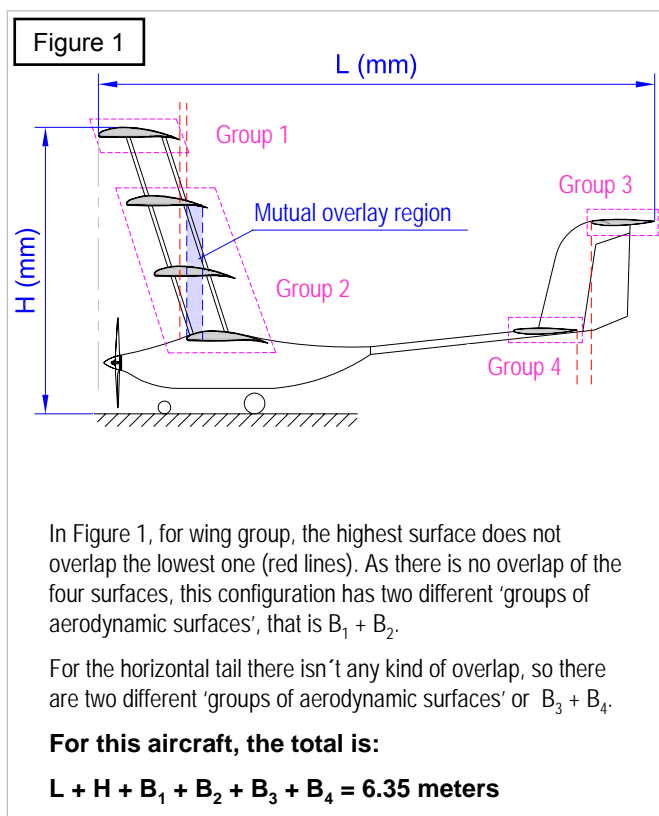

For each *group of surfaces*, only the value of the span (or width) of the biggest element contained in this *group* will be counted. This span is measured between the extreme tips of the biggest element (or aerodynamic surface) found in this group. See Appendix 6.4A, page 75, item iii.

**(1):** For these Regulations, the term “multiplane” includes all of the aircraft with more than one primary or main lifting surface, that is, aircraft with two, three or more wings, one above the other, would be included in this classification.

If the surfaces could be grouped in more than one way, the combination that results in the biggest sum of spans will always be considered. For more information about grouping aerodynamic surfaces, see Appendix 6.4A, page 76, item iv.

**We highly recommend that the teams always take into consideration, during the conceptual development of the project, the worst case scenario for the dimensional inspection (maximum total  $L + H + B_1 + B_2 + \dots + B_n$ ) to ensure that the aircraft is developed with the sum of the dimensions equal to 6.35 meters (250 inches) established by the Regulations.**

Aircraft that exceed the above limit will be subject to the penalties established in Section 2.2.3, page 18, or, according to the situation, they may not even be authorized to participate in the Competition.

The process of the dimensional inspection will be carried out with a measuring tape and with the aid of several special tools (L-shaped squares). The objective of using these tools is to facilitate the measuring process and to minimize errors. All of the measurements will be done in millimeters (mm). The measuring process should not affect the aircraft project. Its measurements must be checked, independently of the configuration set by the team.

Additional plans (“blueprints”) bound with the Report must be sent, clearly showing the measurements set above (See item 5.1.2.2 and Appendix 6.4C). By not sending these plans as required in Appendix 6.4C, the team will be subject to a penalty, according to Section 4.3.1., item 7, page 52. We ask that close attention be paid to the information required on the “blueprints” (see the tables in the sample drawings), because they are extremely important to the dimensional inspection process. By not presenting the required table, the penalties set forth in Section 4.3.1., item 7, page 52, could be levied.

**These “blueprints” should only indicate the main measurements for the dimensional inspection ( $L, H, B_1$  to  $B_n$ ) and all MUST be written in millimeters (mm): International System.**

## 2.2.2. Additional observations

On the same day as the oral presentations, the first dimensional inspection of the aircraft will be performed, following the process that meets the definitions stated above. The aircraft must be present for this verification, totally ASSEMBLED AND COMPLETE, as already described. The teams that want to perform a dimensional inspection on October 16, must go to the dimensional inspection personnel with their aircraft assembled and complete. It is extremely important for the teams, themselves, that all of the aircraft be checked on the first day. The Committee asks for all teams to collaborate and make every effort for this verification to be done on all of the aircraft.

The dimensional inspection may also be performed after each valid flight. It is also the full responsibility of the team to ensure that, from the project phase until final construction, its total maximum **dimensions** ( $L + H + B_1 + B_2 + \dots + B_n$ ) are **EQUAL to 6.35 meters** (250 inches), as set forth in Section 2.2.1. If the aircraft is not projected and built so as to comply with the maximum restrictions, it will be subject to the appropriate penalties set forth in item 2.2.3, or as the case may be, it may even be disqualified.

### 2.2.3. Construction Quality (or Dimensional Precision)

A verification of the dimensional precision will be performed automatically by the scoring spreadsheet, in order to check on the construction quality of the aircraft.

This verification will be based on the difference measured between the maximum total of the dimensions of the aircraft (or 6.35 meters) and the measurement taken by the dimensional inspection personnel.

All of the measurements will be taken in millimeters (mm) with a tape measure and inserted in the scoring spreadsheet in this unit of measurement.

A maximum tolerance (or building error) of -5 centimeters (*minus five centimeters from total of 6.35 meters*) in the total will be permitted, however, construction errors that result in amounts that are larger than 6.35 meters will not be permitted.

The construction quality will, therefore, be considered, as follows:

#### 1. Dimensions of less than 6.35 meters (or < 6.350 mm).

For construction errors of less than or equal to 5 cm, that is, total measurements of up to 6.30 meters (6.300 mm), no penalty will be applied.

For errors greater than 5 cm, or total measurements coming to less than 6.30 meters, a penalty of 0.5 point for every centimeter (cm) will be applied.

#### 2. Dimensions of more than 6.5 meters (or > 6.350 mm).

The final score obtained by the team will have 5 points discounted for every excess centimeter in the overall total of the dimensions ("L", "H" and "B<sub>1</sub>" + "B<sub>2</sub>" + ... + "B<sub>n</sub>").

For example, an aircraft with totals coming to 6.39 meters, or 4 cm beyond the 6.5 meters allowed, will have 20 points discounted from the final score of the team.

All of the aircraft must be checked for their dimensions on Thursday (day of the Design Competition (oral presentations)). It is the responsibility of the team to request the dimensional inspection of the aircraft. The teams have the entire responsibility for getting their aircraft's dimensional inspection before the Flight Competition but, the team that has not had its aircraft evaluated on the first day of the Competition must advise the Technical Committee.

The objective of this first dimensional evaluation on the first day of Competition (or on Thursday) is to register on the score sheet the total sum of the aircraft's maximum dimensions taken before the Flight Competition. Any aircraft that misses the opportunity for this first dimensional verification can only be measured after a valid flight during the Flight Competition days.

This "Construction Quality" requirement will be evaluated after any round of the Flight Competition, meaning that after every valid flight, a new dimensional verification will be made. If the sum of the main dimensions of the aircraft remains within the tolerance (6.30 to 6.35 meters) no penalty will be applied, but if not, penalties will be applied as in the case above. This penalty is valid for the round in which this construction error occurs.

Logically, the dimensional inspection will be performed for the combination of "group of surfaces" where the total is maximum, as set forth in item 2.2.1. and Appendix 6.4A, page 76, item iv.

## 2.3. Required engine

The engine should only be an original K&B .61 RC/ABC (PN 6170) or O.S. .61 FX, glow type and with its original exhaust system. Special engines different from these two will not be accepted. The K&B or O.S. engine for pusher configurations are also permitted. A spacer (or “cap”), or extension between the engine and the exhaust, is permitted.

**Note 1:** It is not allowed to change the carburetor for a similar one, even if it is original for the K&B or O.S. brands, of an older model.

**Note 2:** It is not permitted to remove the internal parts if the muffler. For this, there is an inspection to be performed by the judges at any moment during the Competition.

**Note 3:** It is permitted to use non-original (milled, for example) caps (or extenders between the engine and the muffler), but, in this case, the internal dimensions must be maintained and the drawing of this extender must be very clear on one of the “blueprints” sent along with the Report. An explanation or justification for using this cap must also be included in the Report. The team must request the inspection of the modified cap. If the team does not request this inspection, as soon as the irregularity is found, the team may be automatically disqualified.

**Note 4:** The engine must be acquired by the team, itself, directly from the manufacturers, specialized stores, etc.. The teams interested in getting together for the purpose of buying several engines must contact SAE BRASIL (Technical Committee of AeroDesign).

**Note 5:** The team may have reserve engines.

**Note 6:** It is allowed to use any brand of glowplug, but it is prohibited to use any ignition driven by a spark, or electronic injection.

**Note 7:** It is allowed to change the engine bearings, as long as it is to others that have the same specifications as the originals.

**Note 8:** We recommend that the engine be attached in the conventional manner, that is, with a nylon or metallic mount. Different means of attaching them may be accepted, as long as they meet the specifications of the engine manufacturer. A detailed evaluation of the non-conventional attachments may eventually be required.

## 2.4. Gear boxes, belts and propeller shafts

Gear boxes, belts and propeller shafts are permitted, as long as the rotation ratio between the engine and the propeller is one-for-one. The propellers must turn with the same rpm's as the engine.

SAE BRASIL recommends checking the maximum rotation of the engine, in order prevent damaging it.

## 2.5. Cargo Compartment (or Payload Bay) Limits

The aircraft must have only one compartment for positioning the cargo (or payload). The compartment should have the minimum dimensions of 110 x 160 x 350 mm (4.33 X 6.30 X 13.78 inches), which is enough to completely cover an imaginary block of this size.

When the airplane is ready to fly, the compartment must be totally closed.

The volume of the compartment will be checked after any valid flight, **using a standard rigid block, made of wood, to be furnished and used by the organizers of the Competition.** In order to check the volume of the compartment after each flight, the “payload assembly section” will be removed, and the wooden block will be inserted in the cargo bay that must be completely closed (with all of the fastening devices) for the verification.

**There can be no interference by any of the elements (screws, fasteners, etc.) with the volume defined by the compartment, i.e., with the wood block.**

The compartment may be larger, in order to allow positioning the “payload assembly section” and eventually adjusting the Center of Gravity, but the distribution of the load on the support must comply with the requirements set forth in 2.5.1.

The cargo compartment (or payload bay) may have any configuration that meets the minimum dimensions and the requirements.

Any dimensions of the cargo compartment that are not within the specifications could imply the disqualification of the team.

If possible, the team will have only the flight invalidated, and may make the necessary modifications of the airplane, complying with the procedures for modifying the project and subject to the applicable penalties and other restrictions of the Competition (flight order, qualification rules, etc.).

**Attention:** In order to insert the wood block in the specified internal space of the compartment **it should not be necessary to make even a minimum use of force.** If this occurs for any reason, the cargo compartment will be considered noncompliant with the established minimum limits and the aircraft may even not be authorized to participate in the Competition.

It is the full responsibility of the team to ensure that the dimensions of the compartment have a tolerance (or clearance) so that the block can be inserted without using force. It is not up to the inspectors to make the effort needed to insert the standard block in a compartment that is smaller than the specifications or that has interfering elements that make insertion difficult.

The cargo bay must be clearly shown on one of the plans (drawings), including its dimensions and any and all systems or devices used to attach the “payload assembly section” (together with the payload plates ) in the cargo compartment.

**We recommend reading Appendix 6.1C to better understand the elements regarding some of the details of the bonus for payload fast extraction.**

### 2.5.1. “Payload Group” Distribution

The unit called “payload group” (payload plus “payload assembly section”) **cannot contribute** to the structural stability of the airplane (therefore, it cannot be a part of the airplane’s structure), but it should be fastened in the compartment in such a manner that it will not move during the flight. So, for example, if you do not consider the influence of the CG travel, the aircraft should be “structurally able to fly” without the “payload group” unit.

The distribution of weight in assembling the “payload group” should be evenly spread so that the location of the Center of Gravity of all the payload plates (steel or lead bars) coincides with the geometric center of the “payload assembly section” (U-shaped). That is: the bars cannot be concentrated on one side of the assembly section. **We highly recommend reading Appendix 6.1C.**



It is the responsibility of the teams to provide their own payload plates. The verification of the weight carried will be done after the flight and in the presence of the inspectors. The airplane that does not allow removing the “payload assembly section” for weighing will not have this assembly section weight included in the “payload group”.

The judges will verify if the distribution of the weight on the “payload assembly section” is evenly spread, that is, the “CG” of the bars must be aligned with the “CG” of the assembly section. In other words, the horizontal location (in an X) of the Center of Gravity of the weight bars should coincide with the geometric center of the assembly section. **See Appendix 6.1C.**

The requirements for the dimensions and positioning of the payload plates have several parallels with the challenges normally faced by the engineers of the aeronautics industry, as shown below:

➤ *In the project of a commercial airplane, for example, spaces for the cabin (passengers and crew), fuel and cargo compartments must be designed with the minimum dimensions required to provide passenger comfort, optimized payload and also the quantity of fuel required. Optimization of the internal space is the objective, without compromising the performance requirements of the aircraft.*

*This is the reason why a minimum dimension is set for the cargo bay and, if the compartment does not have the minimum dimensions required, the aircraft may not be considered able to participate in the Competition.*

➤ *As for having no interferences in the systems of the cargo bay, the parallel with the industry is in the fact that several components, systems, conduits, and cabling should be installed in the spaces on the fuselage. These systems must never interfere with the passenger cabin or the cargo bay, for example.*

## 2.5.2. “Payload” and “Payload Assembly Section”

“Payload Group” (or “Useful Load”) is the weight carried by the airplane (Ex.: payload + payload assembly section) and, here in AeroDesign, the total “useful load” will consist of the sum of the weights of the bars (or payload plates) plus the “payload assembly section”. **The weight of the airplane and the fuel are NOT considered as “useful load”.**

We recommend that the “payload assembly section” consist of a “U-shaped” section or a horizontal rectangular plate with two vertical planes on both sides of this first plate. The plates must be made to ensure that the weight is evenly distributed, as required in Section 2.5.1 (Regular Class).

Appendixes 6.1A and 6.1B show an example of how the “payload assembly section” and the payload plates can be positioned and, as already mentioned, we highly recommend reading Appendix 6.1C.

If the team should eventually not use any kind of “payload assembly section”, or if it cannot be released from the aircraft, only the payload plates will be considered as “useful load”. We always recommend using a “payload assembly section”, as indicated above, for safety reasons, for fastening the bars, themselves, and them to the structure of the aircraft. It is important to remember that a block of wood will be inserted in the space of the cargo bay, for the verification process, and, therefore, no element of the “payload assembly section” or of the compartment itself, may interfere with a complete insertion of the block.

## 2.6. Gyroscopes

The use of gyroscopes of any type will **not** be permitted for the Regular Class.

Obtaining an aircraft with good flight characteristics (or adequate “quality of flight”) is a part of the challenge. It is the full responsibility of the team to develop a project where the aircraft meets these requirements naturally.

## 2.7. Additional Requirements – Regular Class

### 2.7.1. Radio Control

Radio control will be used to fly and maneuver the airplane. The flight will be held, rain or shine. For this reason, the teams must prepare to weatherproof the radio equipment.

All of the radios must comply with **FCC** (Federal Communication Commission – the U.S. telecommunications agency) and AMA 1991 (Academy of Model Aeronautics) rules for model airplane frequencies. This is a narrow-band system and is identified by a gold sticker on the unit.

We also recommend that the teams use narrow-band receivers to minimize potential problems.

The radios must be in good operating condition. The safety inspectors could keep the airplane from flying, if they feel that the radio is not in acceptable operating condition.

For the Regular Class **WE RECOMMEND** using a PCM (Pulse Code Modulation) radio, whose technology is less susceptible to interference.

**The teams from the Regular Class that opt to use the PCM radio will gain one (1) extra point.** It should be clearly demonstrated during the safety inspection which type of radio is being used.

**Attention: For 2009, the use of a PCM radio will be mandatory for all of the teams (Regular and Open Classes)**

The inspection of the radio system, as well as all of the electronics of the aircraft, will be done by an expert inspector / judge.

It is allowed to use more than one receiver, if necessary.

Special recommendations and RULES regarding the safety of the Radio Control and the electronic installation of the equipment will be explained in detail in the document “Regulations and Good Safety Practices – SAE AeroDesign 2008”, which will be issued in good time. **Any doubt can be resolved by E-mail, as shown in page IX, Part I, above.**

**Attention: All of the radios (including the reserves) MUST be turned in to the Radio Tent by 7:30 a.m., every day of the Flight Competition. The teams that do not turn in the radios by this time will lose 20 points per late day.**

It is very important to have the collaboration and efforts of everyone so that the Competition runs quickly and smoothly. The flights may only begin after collecting all of the radios. We repeat: the success of the event depends on everyone.

Events not controlled by the Technical Committee could occur, making it necessary to reevaluate the procedures for collecting the radios. We are counting on the understanding and collaboration of everyone in this type of situation.

### 2.7.2. Battery pack

A 500 mAh pack is usually the minimum allowed for the Competition. The batteries may be charged at any time on the ground, as long as they follow the safety standards for each type.

The types of batteries allowed are:

- ✓ Nickel Cadmium (NiCad)
- ✓ Nickel-metal Hydride (NiMH)
- ✗ Lithium Polymer (LiPo): this battery has serious safety recommendations. Risk of explosion or fire, especially during charging or in high temperatures (50° C (possible temperature inside the aircraft under a hot sun)).

**For more information regarding the characteristics of the batteries and safety standards, consult the “Regulations and Good Safety Practices – SAE AeroDesign 2008”.**

### 2.7.3. VoltWatch installation

As of 2008, the teams in the Regular Class that choose to install a “**VoltWatch Receiver Battery Monitor**” (or onboard tension meter) **will gain one (1) extra point.**

**As of 2009 the “VoltWatch” will be mandatory for all aircraft.**

The VoltWatch is used to check the battery load without using auxiliary equipment, and the main objective is to provide increased safety and to speed up the verification of electronic safety.

Example of a VoltWatch:



**VoltWatch makes it possible to check the battery charge at any time during the Competition, including on the runway during the last check of the flight controls, just before takeoff.**

**It is mandatory to use a commercial VoltWatch.**

Even though this equipment could be built by the team, for the purpose of reliability and safety, it is mandatory to use commercial (or certified) equipment by a manufacturer.

**Attention:** VoltWatch is safety equipment and if the teams choose to gain one (1) extra point, it should be permanently installed on the aircraft, that is, it cannot be removed. This item will be checked before all rounds in the Flight Competition and if this equipment is not found, the aircraft will no longer be able to participate in that particular round and the extra point may be canceled for that team. It will not be permitted to install VoltWatch during the safety inspections.

#### 2.7.4. Engine inspection

Engine inspection and checks may be done by the judges of the Competition at any time.

#### 2.7.5. Propellers

Multiple propellers, covered propellers, and ducted fans are allowed. However, it is **prohibited to use metal propellers**. The propeller should be fastened with a standard bolt (which accompanies the engine). A spinner or self-locking nut should be added (MANDATORILY) for the purpose of increasing the safety of the fastener. Although the solution developed by the engine manufacturer to fasten the propeller to the engine shaft is safe, the Technical Committee reserves the right to REQUIRE redundancy in the fastening, in order to increase safety.

The teams that want to use propellers manufactured by the team, itself (not commercially made), with any number of blades, must submit a two-page Report, together with the Project Report, to the Technical Committee, showing:

- A safety analysis, including a theoretical analysis.
- Tests performed, test devices.

We highly recommend performing tests at the maximum rotation limit set by the manufacturer of the engine to be used by the aircraft. We suggest that the maximum rotation time not be less than five (5) minutes.

- The operational envelope taken into consideration.
- Details demonstrating that the concept and construction of the propeller are sufficiently safe.

The team is responsible for checking the aspects that should be analyzed and tested. This Report will be checked by a safety judge and will not be a part of the project score. If the judge's analysis points out that the propeller is unsafe, the team will be advised within no more than 30 days after the Report is sent.

**The lack of this Report will keep the team from participating in the Competition, when using propellers manufactured by the team, itself.**

#### 2.7.6. Fuel and Fuel Tank

The fuel for the Regular Class will contain 10% nitro methane and will be supplied by SAE BRASIL.

The fuel tank must be accessible for visualizing its contents during inspection. The fuel should be pressurized by normal means, only, that is, without the use of a pump. The tank will be emptied and refilled before each flight by the inspectors of the Competition.

**It will be totally filled, whatever the size of the tank. The proven occurrence of a fuel shortage during the flight, will invalidate the flight.**

To weigh the empty aircraft, which is necessary for determining the Structural Efficiency Factor (EE) (item 2.9.3.), the fuel may be removed from the tank only at the appropriate stand and accompanied by an inspector.

We recommend using commercial tanks, in order to facilitate the safety inspection.

We also recommend that the interior of the tank be visible, even if only partially. Very transparent tanks may not be accepted.

### 2.7.7. Use of a Tail chute or Parachute

Due to the inherent risk that this type of equipment could present, its use is prohibited, whether as a landing or emergency device.

### 2.7.8. Control Surfaces

The control surfaces cannot have excessive backlashes in their hinge points, because this tends to reduce controllability, in most cases, and in more severe cases they generate flutter. The number of hinge points should be proportional to the wingspan and the acting loads on the surface.

### 2.7.9. Servo Sizing

Analyses and/or tests should be presented in the Project Report, showing that the servos (or electric actuators) used on the aircraft have adequate dimensions and are capable of supporting, or are greater, within a certain margin, than the aerodynamic loads to which the airplane will be subjected during the flight. **We recommend that special attention be given to all of the elements of the servos, such as, gears and the joint between the “servo arm” and its “servo axis”. Low quality components could break, causing the loss of the torque transmitter element which results in a “moment equal to zero” or, in other words, a loss of control.**

### 2.7.10. Flight Video (bonus) and Qualifying Flights

With the objective of encouraging the teams to exhaustively evaluate their aircraft as far in advance, as possible, besides positively seeking safer aircraft, the Technical Committee established, in 2006, an additional bonus (extra points) for the teams that send in a complete flight video of the aircraft. Upon observing the excellent results coming from this new bonus, over these years, we see that the prototypes brought to the Competition, besides being more refined and safer, have had pilots who are very well trained, thus bringing greater safety to the Competition.

This resulted in the bonus for 2008 being increased by one point. Therefore:

The teams that send a complete flight video (continuous filming, with no editing and of good quality) **up to 15 consecutive days before the Competition**, will receive a maximum of **five (5) points in the final score of the Competition**.

**Attention:** the amount of the extra points (or bonus) will be not only for the technical quality of the video, but also for the possibility of visualizing the flight characteristics of the aircraft. Sending the video does not guarantee an automatic bonus of five (5) points. The video will be analyzed by judges indicated to decide the amount of the bonus. The grade for this bonus is final, and cannot be protested.

The videos should be sent in the \*.wmv (or Windows Media Player) format.

Qualifying flights in São José dos Campos, on the eve of the Competition, are not required for aircraft in the Regular Class. However, some teams may not have sent this video, and may be requested by the Technical Committee, to send demonstration videos of one complete flight (standard flight circuit). If this request is not met, the team may lose up to five (5) points.

### 2.7.11. Maximum Eligible Weight

Aircraft of the Regular Class cannot have a total weight (empty weight + maximum payload + fuel weight) greater than 20 kg (44.09 lb.).

It is the team's responsibility to comply with this maximum limit. If, after the flight, it is found that the weight of the aircraft, plus the load being carried (*PV* + *CP*) exceeds this limit, the flight will be invalidated and the aircraft may even be disqualified.

*PV* means Empty Weight (or *Peso Vazio*) and *CP* means Total Payload (or *Carga Paga*). In this case the fuel weight is part of the empty weight.

## 2.8. Takeoff Distance – Regular Class

### 2.8.1. Introduction

Always focusing on constantly perfecting the teams within the field of Aeronautical Engineering, the Technical Committee proposes a challenge for 2008, in the form of a new concept in AeroDesign Brazil called the "Segmented Runway".

This new requirement, together with other already established ones, will most certainly place the teams from the Regular Class in contact with a new reality in AeroDesign, which is to effectively and in a multidisciplinary manner seek the best aircraft for the SAE AeroDesign Competition.

### 2.8.2. "Segmented Runway Concept"

The challenge of this "segmented runway concept" consists in dividing the normal runway (61 meters) into two equal segments, which will be called **Section 1** and **Section 2**, respectively.

The runway Sections will be set as follows:

**Section 1** → Takeoff line, up to 30.5 meters;

**Section 2** → The 30.5 meter line, up to 61 meters.

Whatever the direction of the takeoff, the first Section will always be the one that begins the takeoff run.

Each of these Sections will be given a score per unit of weight carried, or points per kilo (points/kg). The score given for Section 1 will always be bigger than the score for Section 2. Regarding the score amounts, see item 2.9.1, below.

If the team is unable to take off within Section 1 (or within 30.5 meters), the score to be given will logically be that of Section 2 (or 61 meters). If the 61 meter limit is passed, the attempt is invalidated. The limit for takeoff, for a valid flight, remains at 61 meters (or 200 feet).

Two accuracy curves (Section 2.9.2, page 27, and 5.1.4.1, page 63) may be sent, so that the team has a chance to validate its project (and its calculations) on each of the Sections. It is necessary that the curves be set for each of the Sections, that is, the curves must be distinct from one another.

If the team chooses to “operate” in only one of the Sections, and to send only one accuracy curve, this score will not be counted for the other Section.

For more information regarding the plot standard (or plot format), consult Section 5.1.4.1., page 63, and Appendix 6.2, page 73.

The runway Sections will be divided by a yellow or red strip (whichever provides the best contrast with the local asphalt).

So that the score for the first Section is counted, the aircraft must take off visibly, before reaching the dividing strip of the Sections. If there is any doubt, the next Section will always be considered, or the one with the lowest score per kilo carried.

To become familiar, in detail, with the control and verification procedures regarding which Section the aircraft took off from, consult the “Operational Procedures – SAE AeroDesign 2008”, which will be released in good time.

**The “Segmented Runway Concept” is valid ONLY for the Regular Class and ONLY for the takeoff.**

## 2.9. Points – Regular Class

### 2.9.1. Maximum Payload Flight Score

The Flight Competition consists of several rounds in which the teams will attempt to carry the biggest possible weight. The number of points in this phase will be based on the maximum “useful load” carried on a totally valid flight (see Section 4.1.5, page 44) and will be calculated for each of the Sections in the following manner:

**SECTION 1: 1 point per 0.077 kg**

**SECTION 2: 1 point per 0.125 kg**

### 2.9.2. Accuracy – Points

Additional points will be added for the Open and Regular Classes, based on the exactness of the “useful load” prediction. The score resulting from the accuracy of the estimated “useful load” is calculated according to the following formula, with the weights of the “predicted useful load” and “real useful load” expressed in kilograms (kg):

$$\text{Points: } [30 - 10 \times \text{abs} (\text{Predicted Useful Load} - \text{Real Useful Load})^{1.5}]$$

and as long as the expression is a positive value. Otherwise, the score will be equal to zero (0).

For 2008, the maximum score set for accuracy will be 30 points.

**The accuracy will be validated for both Sections, as long as the team has presented two distinct curves. Otherwise, the curve will be valid only for one of the Sections, chosen by the team. This Section MUST be shown on the graph, along with its respective curve (See Section 5.1.4.1.). The lack of information regarding which Section was considered as a project point by the team will cause Section 2 to be considered.**

For more information about the type of graph consult Section 5.1.4.1., page 63, and Appendix 6.2, page 73.

### 2.9.3. Structural Efficiency Factor – Additional Points

Additional points for the Regular Class will be added, based on the Structural Efficiency Factor, that is the result of quotient between the “useful load” (CP) / aircraft empty weight (PV).

With the objective of encouraging a more technical approach for the teams’ efforts in their search for greater structural efficiency, the final value of the bonus, as was done in 2007, will be related to the final Report grade obtained by the team. The Committee hopes to encourage that all of the solutions adopted for reducing the weight of the aircraft be obtained on strong technical (or engineering) bases.

The additional points (bonus) are calculated with the following equation:

$$Points = 2,5e^{EE^{0,75}} \times \alpha \quad \text{for } EE > 0.$$

(Points = 2.5 x “Napierian Log” raised to Factor EE, which is then raised to 0.75)

Where alpha ( $\alpha$ ) is set as:

$$\alpha = \frac{NR}{NM} \quad \text{being:}$$

- *NR*: Final Report grade (or “Nota do Relatório”) obtained by the team
- *NM*: Maximum Report grade (or “Nota Máxima”) (or total possible points: 165).

The Structural Efficiency (or “Eficiência Estrutural” (EE)) factor will be calculated in the following manner:

$$EE = \frac{CP}{PV}$$

where:

- CP is the total payload (“useful load”) (kg)
- PV is the aircraft empty weight (without fuel <sup>(1)</sup>) (kg).

The purpose of this relationship between the Structural Efficiency factor and the project score (Report) is to see that the teams actually justify all of the project decisions that culminated in reducing the weight of the aircraft, whether they are structural, systemic, or even aerodynamic.

---

**(1):** It is the responsibility of each team to request, at the appropriate stand, the removal of the fuel from the tank for weighing the aircraft. This fuel may only be removed under the supervision of an inspector. The fuel which is removed should be stored in an appropriate bottle, and this bottle is prohibited from leaving the “fuel area”. **The removal of the fuel from the tank should always be done under the supervision of the fuel inspector.**

We recommend always using gloves when handling the fuel.

---

The EE factor is an incentive for structural optimization, that is, lighter structures with naturally smaller safety margins. We recommend, therefore, that extreme care be taken in determining the loads acting on the aircraft, as well as the structural project of its primary elements, such as, spars, fuselage – tail cone connection, and other items.



**With this bonus, a very realistic approach to the work done in the Aeronautics Industry, where the issue of reducing weight by optimizing the structure and installing only truly necessary equipment, is a constant challenge for the engineers and technicians involved in the project of an aircraft, whatever type it may be.**

**Attention:** It is always appropriate and recommended to check the “Regulations and Good Safety Practices” before beginning a project, especially those items that could interfere in the decisions of the team about reducing the weight of the aircraft.

#### 2.9.4. “Quick Payload Removal” – Additional Points

After each valid flight, the operation of opening the cargo bay (or cargo compartment) for a fast removal of the “Payload group” (or “useful load”) will be timed, and bonus points will be given to the teams that are able to perform the entire operation in up to 10 seconds, according to the following equation, with the “time” variable expressed in seconds:

$$Points = 10 - 3,17 \times \sqrt{time}$$

The points will be given, as long as the equation gives a positive score. If the total payload (“useful load”) is not removed in less than 10 seconds, the score will be zero (0).

For bonus purposes, only one member of the team may open the cargo bay, from an initial standing position, next to the aircraft, which will be positioned with the center of its compartment in the center of the square marked on the ground. For more details, see: “Operational Procedures SAE AeroDesign 2008”, to be released as soon as possible. **Any question about this must be sent to the E-mail shown on page IX, Part I, above.**

It is prohibited to use any type of cutting tool (scissors, knife, or the like) to cut the lid or any other component, when opening the cargo bay. Every part or component of the cargo bay or the cargo bay door, should be able to be used again, therefore it cannot be destroyed during the opening, even if by mistake. The latching systems of the cargo bay should be able to be reused without changing their characteristics.

**We strongly recommend that the door of the cargo bay be a structured element and not merely a plastic film, glued or attached to the fuselage. If a component of the aircraft should come loose during any flight phase, it will be considered invalid.**

**The time used for calculating this bonus (to be used in the final score) will be that of the best round of the team.** Greater detail will be given in: “Operational Procedures – SAE AeroDesign 2008”.

**This is not a mandatory item.** These additional points will be a team choice.

#### 2.9.5. “Minimum Volume Box” – Additional Points

In 2007, an additional challenge was proposed to the teams, for a bonus. This new challenge was stimulated by the accelerated development of the UAVs in recent years, and is closely related to the exceptional transportation logistics needed for this type of aircraft.

This challenge consists of designing an aircraft that, when disassembled, takes up the smallest possible volume. This volume is set to be a box (a rectangular prism or also called a *cuboid*) whose sides must be perpendicular to each other and the Length (L), Width (W) and Height (H) measurements must correspond to the internal dimensions of this box.

The box should be built by the team and its walls must have no deformities and be as flat as possible. The internal measurements considered will be the largest, or those that form the biggest volume.

The aircraft must come disassembled in any number of subsets, which must be totally contained inside the box.

Subsets are established, here, as the large elements of the aircraft: Ex.: wings, fuselage, etc.. The aircraft cannot be totally disassembled inside the box, that is, the subsets must only be assembled, bolted or boxed, but CANNOT be glued. The aircraft must come as the final product. For example, we do not recommend there be more than 15 subsets.

The points will be calculated with the following equation:

$$Points = 15 \times 0,91^{(ranking\ position-1)}$$

Where the emphasis is on the inverse order of volumes, that is, from the smallest volume (first place or 15 points) to the biggest volume (30<sup>th</sup> place).

**The bonus granted will be no more than 15 points.**

The bonus will only be granted to the thirty (30) smallest volumes among all of the aircraft participating in this item. The 31<sup>st</sup> receives no score.

The team must attach additional plans to each of the copies of the Report, three views (see Appendix 6.5, page 80) showing how the aircraft<sup>(1)</sup> is packed in the box. In the upper right hand corner of these plans there should be a table containing the internal measurements of the box (L, W and H), the volume calculated with these measurements, the total number of subsets and a list of the subsets.

The list of subsets must include all of the elements needed to completely assemble the aircraft (even the bolts packed in the box must be listed on the table). We recommend packing these small elements in plastic bags and, eventually, separated and listed in groups (ex.: bolts for attaching the main landing gear or for attaching the wing to the fuselage, etc.).

The engine cannot, by any means or in any situation, be separated from the fuselage, or the structure of the fuselage, no matter how it is attached. The propeller may come separate from the engine.

The volume of the box will be checked (and measured) by a group of inspectors who specifically have this function. The box should be opened in the presence of these inspectors, who will also be responsible for checking the subsets in the box and the list of them on the additional plans sent. No element for the complete assembly of the aircraft must be lacking. All of them must be packed in the box.

Only one team member opens the box and shows the inspector all the subsets listed on the additional plans sent, taking them from the box in the order in which they are listed, if possible.

**We suggest that the teams “think commercially” when organizing the aircraft (or its subsets) inside the box. It should be similar to a kit, to be assembled or connected.**

**This is not a mandatory item. These additional points will be a team choice.**

---

(1): If the team decides to protect the aircraft inside the box with Styrofoam, foam rubber or any element not related to aircraft, it must NOT be listed on the plans. The plans should only show the elements (or main elements) that truly take up the volume of the box.

### **3. Requirements – Open Class**

#### **3.1. Eligibility – Team members**

The OPEN CLASS is limited to **undergraduate and graduate students (*stricto sensu*)** in Engineering, Physics or Aeronautical Sciences, members of SAE BRASIL.

Any team, whether national or international, which is registered in the OPEN CLASS must have among its members **at least three** veteran students of AeroDesign, that is, students who have a history of at least one **complete participation**<sup>(1)</sup> in former AeroDesign Competitions, in either the Regular or the Open Class. The Schools or teams that do not totally match the item, above, that is, do not have students who have a history of a complete participation, will only be eligible to participate in the Regular Class.

**Students who graduated (or finished graduate studies for the Open Class) in the school semester immediately preceding the Competition are NOT eligible to participate. It is mandatory that the documentation regarding enrolment in 2008, be sent accordingly Sections 5.1 (page VIII) and 5.2 (Page IX) above.**

**All of the members of the team must be members of SAE BRASIL, and the membership card or other document that proves they are members could be required during the Competition. Information on how to become a member is available at [www.saebrasil.org.br](http://www.saebrasil.org.br).**

**For any additional questions about these matters, send an e-mail to the address shown on page IX, Part I, above.**

**(1): Complete participation** is understood to be that which allows the student to go through all of the phases of AeroDesign, that is: aircraft design, construction of the prototype, tests and participation (actual and proven) in the theoretical and Flight Competition.

#### **3.2. Engine**

The airplanes of the Open Class can have more than one engine, but the total engine displacement (or sum of displacement of all of the engines) cannot exceed 15.08 cm<sup>3</sup> (0.92 cubic inches). Any brand of engine may be used. These engines may be prepared internally, as long as their displacement is not changed.

The team must, of necessity, include, as an attachment to the Project Report, the documentation of the manufacturer of the engine(s) that indicate the cubic capacity of the engine, as well as a descriptive text about the modifications performed on the engines.

The total number of pages given to this attachment will not be counted as part of the Project Report.

**Airplanes whose engine displacement is more than what is allowed will not be eligible to participate in the Competition and will be disqualified.**

**It is allowed to use special pumps and special mufflers (tuned pipes), or similar.**

**It is allowed to use engines with electronic injection, and 4-cycle engines.**

### 3.3. Gear boxes, belts and propeller shafts

Gear boxes, belts and propeller shafts are allowed. The ratio of the rotations between the engine and the propeller can be different from one engine to the other. The propellers do not need to have the same RPM as the engine.

### 3.4. Payload Group (or “Useful Load”)

The “payload group” (payload plates + payload assembly section) cannot contribute to the structural stability of the airplane (therefore, it cannot constitute a structural element of the plane), but it should be attached to the compartment so as to keep it from moving during the flight.

For the Open Class, it is not necessary for the Center of Gravity (CG) of the payload plates to coincide with the CG of the “payload assembly section”, and the weights can be used to balance the model with the correct CG.

We suggest the use of a “payload assembly section” similar to that used for the Regular Class.

### 3.5. Gyroscopes

The use of gyroscopes and of any type of automatic control system is allowed for the Open Class.

### 3.6. Fuel and Fuel Tank

For the Open Class, besides the standard fuel, furnished by SAE BRASIL, it is allowed to use fuel with different proportions of nitromethane, as long as it is a commercial fuel<sup>(1)</sup> that is appropriate for model airplane flights. In this case, it must be furnished by the team, itself.

The fuel tank must be accessible (and not only visible) for determining its content during inspection and for checking all of its connections. We recommend that the(se) tank(s) allow visualizing their interior, that is, they must be totally transparent.

Tanks where visualization of its internal components (fuel collector filter, hoses and the fuel, itself), even if partial, is not possible, may not be accepted.

The fuel can be pressurized by normal means or by using pumps. The fuel tank will be emptied and refilled before each flight, by the inspectors of the Competition.

The tank will be entirely filled, whatever the size of the tank. The PROVEN occurrence of a fuel shortage during the flight will invalidate the flight.

More information regarding the fuel for the Open Class and the pertinent safety requirements may be seen in the “**Regulations and Good Safety Practices - SAE AeroDesign 2008**”, which will be updated and released in good time.

---

(1): It is understood that **commercial** fuel is that which is produced by a certified company allowed to manufacture these kinds of products. Ex.: Byron.

For the OPEN CLASS, when using fuel that is different from what is normally used in the Competition, the teams are required to present the following items, at least one month in advance of the Competition<sup>(2)</sup>:

- A “Report” (one page or less) with the specifications of the fuel (technical designation, manufacturer, characteristics and/or formula) so that the Committee can attest that it does not offer any risk to the Competition. This “Report” can be sent via E-mail.
- An invoice (copy) or similar document referring to the purchase of the fuel must be presented, if the team is questioned regarding the fuel acquired. We recommend that, together with this invoice, the specifications of the fuel be presented, as described above.

(2): In fact, we recommend that these documents be sent together with the Report (in the same mailing).

**It is forbidden to use mixed fuels, whatever they may be. If any irregularity is found with the fuel used by any team of the Open Class, the team could be severely penalized or even disqualified.**

**The use of gasoline engines is prohibited.**

Procedures for handling the fuels of the OPEN CLASS during the Competition:

- ➔ The teams must return to the fuel station (or fuel area) ALL of the sealed containers (or as they were when purchased) that will be used in the Flight Competition. These containers must be identified with the number and the name of the team, as well as that of the Educational Institution to which the team belongs. We recommend not attaching this identification to the label naming the type of fuel.
- ➔ The refueling or defueling may be done by the team, itself, using its own pump and under the supervision of a trained inspector. THE TEAM IS NOT ALLOWED TO PUT FUEL IN OR REMOVE IT FROM THE TANK WITHOUT THE PRESENCE OF AN INSPECTOR.
- ➔ If the refueling or defueling is done by an inspector (only the Team’s pump should be used), we highly recommend that the team closely accompany this process, in order to aid the “fuel inspector” when needed.

We recommend using commercially produced fuel tanks to facilitate the safety inspection.

## **3.7. Specific Safety Requirements**

### **3.7.1. Radio Control**

Radio control will be used to fly and maneuver the airplane. The flight will be held rain or shine, so the teams must weatherproof the radio equipment.

All of the radios must comply with FCC and AMA 1991 rules for model airplane frequencies. This is a narrowband system and is identified by an gold sticker on the unit. We also recommend that the teams use narrowband receivers to minimize potential problems.

The radios must be in good condition. The safety inspectors may keep the airplane from flying, if they feel that the radio is not in acceptable condition.

For the Open Class it is **mandatory** to use a PCM (Pulse Code Modulation) radio, whose technology is less susceptible to interference. These radios also have safety mode instructions, i.e., in the case of a radio signal failure, a preset program moves the surfaces of the aircraft to a predetermined safe condition, until the signal returns.

Special recommendations regarding safety, involving Radio Control and electronic installation, to be issued in good time and specifically for the Open Class, **will be mandatory.**

**Attention: All of the radios (including the reserves) MUST be turned in to the Radio Stand by 7:30 a.m., on all of the days of the Flight Competition. The teams that do not turn the radios in by that time will be penalized 20 points per day late.**

It is very important that everyone collaborate and make every effort for the Competition to be quick and organized. The flights may only begin after all of the radios have been collected. We repeat that the success of the event depends on everyone.

Events beyond the control of the Technical Committee could occur, meaning that the collection process of the radios could eventually be reevaluated. We count on the understanding and collaboration of everyone in situations of this type.

### 3.7.2. Receiver and Battery Packs

#### 3.7.2.1. Receiver

For the aircraft in the Open Class it is **MANDATORY TO USE TWO RECEIVERS** or some other form of backup for the radio.

#### 3.7.2.2. Battery packs

**A pack of 1000mAh (1Ah) FOR EACH RECEIVER USED** is the customary minimum permitted for the Competition in the Open Class.

It is permitted to use multiple batteries, as long as the minimum charge of 1Ah is achieved for each receiver.

The types of batteries allowed are:

- Nickel Cadmium (NiCad)
- Nickel-metal Hydride (NiMH)

The batteries may be charged at any time on the ground.

**Lithium Polymer (LiPo) batteries are not allowed in aircraft in the Open Class.**

For EACH ONE OF THE RECEIVERS USED, it is **mandatory** that a “*VoltWatch Receiver Battery Monitor*” (or an onboard tension meter) be installed.

The VoltWatch makes it possible to check the battery charge at any time in the Competition, including on the runway during the last check of the flight controls, just before the takeoff.

Example of a VoltWatch:



**Attention:** The VoltWatch is mandatory safety equipment and must be permanently installed on the aircraft, that is, it cannot be removed. This item will be checked in the safety inspections before every flight competition round and if this equipment is found lacking, the aircraft will no longer be able to participate in that round. The VoltWatch will not be allowed to be installed during the safety inspections.

**For the Open Class it is mandatory to use a commercial VoltWatch.**

Even though the equipment could be built by the team, because of reliability and safety issues, it is mandatory that commercial (or certified) equipment by a manufacturer be used.

Additional recommendations regarding the batteries can be seen in: "Regulations and Good Safety Practices – SAE AeroDesign 2008".

### 3.7.3. Additional Requirements – Electronic Systems

The airplanes of the Open Class must comply with the following safety requirements:

- Wiring compatible with distance and current (show the electrical diagram in the Report).  
This electrical diagram will be evaluated by an expert judge.
- In the case of extensions built by the team, observe the following aspects:
  - ✓ No type of soldered connection is allowed.
  - ✓ All of the connections must be made with male/female connectors.
  - ✓ All of the connections of the connectors with the wires must be crimped.
  - ✓ The recommended connectors are the MODULE 3-way type, or equivalent.
  - ✓ The recommended wires for making the servo / energy extensions are of the AWG 24 or AWG 26 type, non-rigid wire.
- The control systems (servos) must be segregated, that is, distributed by the two receivers. If one of the receivers of the aircraft should fail, it should still be controllable, even if only partially.
- Battery for heating up the glowplug in low RPM conditions of the engine: this is an optional equipment, but it is highly recommended.

Additional recommendations and requirements regarding the electrical-electronic installations can be found in the "Regulations and Good Safety Practices – SAE AeroDesign 2008".

### 3.7.4. Additional Requirements – In General

- All of the bolts for attaching the critical components (landing gear, wings, stabilizer, etc.) must have self-locking or wire locked nuts.  
We suggest you always consult the “Regulations and Good Safety Practices – SAE AeroDesign 2008”.
- The surface linkage must be compatible with the aerodynamic loads, and the number of links on each surface should be compatible with the wingspan.

**Critical cases have been observed, as a result of not taking these items into consideration. See items 3.7.11 and 3.7.12.**

### 3.7.5. Single-engine flight test

In addition, the teams of the Open Class must furnish, **within 30 days** before the Competition, a Report of no more than two pages, detailing the theoretical analysis and practical tests for the case of losing one of the engines under the most critical condition.

At least one test flight should be held in this condition, and the results must be presented in this Report. The team is responsible for identifying the most critical condition, checking the necessary analyses (considering the dynamics of the failure and the pilot’s viewpoint), and how the test should be carried out.

**We recommend that this flight be performed with at least the classification payload, that is, 8 kg.**

### 3.7.6. Flight Video

A video must be sent, recorded in CD or DVD format, clearly demonstrating that under normal conditions, or with all of the engines running, the aircraft is safe, maneuverable and capable of carrying out at least one complete flight path, as established in Section 4.3.1. The complete flight (takeoff, one lap around the field and landing) must be filmed in its entirety (continuous filming, no editing and good quality). The aircraft should be visible during the entire flight.

**The videos must be sent in the format: \*.wmv (or Windows Media Player)**

**We recommend that the video include a complete visualization of the aircraft before or after the flight, including the cargo bay (for payload visualization).**

**We also recommend that this video be made with the aircraft loaded with the classification payload (8 kg), or higher.**

This video **MUST** be sent **up to 20 consecutive days before the Competition (or September 26)** and will be a mandatory requirement for participating in the Open Class in 2008.

**The main objective of this video is to demonstrate that the aircraft at the Competition will present safe flight characteristics and will not be a risk to the competitors and crowd in attendance. The Organizers of the event encourage all of the aircraft in the Competition (of the Open or Regular Class) to be exhaustively tested, not only for safety purposes, which is a basic and mandatory factor, but also because of the educational aspect characteristic of this phase. It is during this important phase of the tests, done well before the Flight Competition, that the project can be refined, increasing its degree of success and its competitiveness.**



### 3.7.7. Qualifying Flights

The airplanes of the Open Class may also be subjected to prequalification checks and tests to ensure that they are safe to fly during the Competition, in the presence of the crowd and competitors. The teams will be advised, in advance, of the details of this test. For scheduling purposes, the teams must be prepared to perform this test by the eve of the Flight Competition, that is, by Thursday, when the projects are presented.

### 3.7.8. Project Follow-up and Validation

For 2008, the Technical Committee plans to continue, and even expand, the **Follow-up and Validation Process** applied to the airplanes of the Open Class. The objective of this process is to ensure, prior to the Competition, that the airplanes (products) competing in this Class show the necessary consistency and maturity in relation to the original project, thus benefiting safety, as a whole.

**The Follow-up and Validation Process for 2008 will be done in two phases:**

**The first phase** – consists of sending an additional Report called "Follow-up Report", via E-mail or postal services (paper or CD), by September 1 (Monday), that must explain, in detail, the compliance with items required by the list of "Minimum Requirements for the Project and Tests – Open Class – SAE AeroDesign 2008", available under "Rules and Reports" on the page dedicated to the AeroDesign Competition on the SAE BRASIL site.

The list details requirements and provides tips on how the Follow-up Report should be written. Its objective is to guide the teams to develop the most complete and project which is philosophically closer to what is done in the aeronautics industry, focusing on smaller aircraft. They are like the certification requirements for AeroDesign 2008. These Minimum Requirements will be considered mandatory.

With this additional Report, required after the date for turning in the Project Report, it is hoped to obtain complementary information with greater quantity and quality, because of the maturing of the tests performed with the aircraft, compared to the period of preparation of the Report.

**The second phase** – consists of a series of visits to the teams (Brazilian Teams) by a representative of the Technical Committee of SAE AeroDesign, in order to check on the characteristics of the project.

We must point out that the series of visits will be directly related to the amount of information presented in the documents sent: Project Report and Follow-up Report. In other words, the more complete and consistent the evidence that the required items have been fulfilled, the less priority will be attributed to a visit to the team.

**All of the visits will be scheduled in advance and will take place from 40 to 50 days before the Competition.**

The process takes in, to start with, a prior check of the aspects of the project, via the Minimum Requirements, such as: predicted loads and structural calculations, photos of the structural tests performed, as well as a few photos of the building process. All of these items will be a part of the documentation to be audited.

Greater detail will be released in good time, via specific bulletins. Remember that the primary objective of AeroDesign is educational, that is, this should contribute to the formation of the future professional in the area of Aeronautical Engineering. Interpreting and meeting requirements is a part of the daily work of an Aeronautical Engineer.

### 3.7.9. Propellers

Multiple propellers, shrouded propellers and ducted fans are allowed. However, it is **prohibited to use metallic propellers**. The propeller should be attached with a standard nut (that comes with the engine). A mandatory spinner or self-locking nut must be added, in order to increase safety. Although the solution developed by the engine manufacturer for attaching the propeller to the shaft of the engine is considered safe, the Technical Committee reserves the right to REQUIRE redundancy in this attachment, in order to increase safety.

The teams that want to use propellers manufactured by the team, itself (not commercial), with any number of blades, must submit a Report of no more than two pages to the Technical Committee, along with the Project Report, showing:

- A safety analysis, including theoretical analysis.
- Tests performed, test devices.
- The operational envelope considered.
- Details that show that the concept and the construction of the propeller are sufficiently safe.

The team is responsible for checking the aspects that should be analyzed and tested. This Report will be checked by a safety judge, and will not be a part of the project score. If the analysis of the judge concludes that the propeller being checked is not safe, the team will be advised no more than 15 days after the Report was sent.

**Sending this Report, by the required deadline, is a mandatory condition for participation in the Competition by a team that chooses to manufacture its own propellers.**

**It is mandatory that the analyses cited above be done also for commercial single-blade propellers.**

### 3.7.10. Use of a Tail chute or Parachute

Due to the inherent risk that this type of equipment can pose, it is prohibited to be used, either as a landing or an emergency device.

### 3.7.11. Control Surfaces

The control surfaces must not have backlashes in the surface links. Control surfaces with backlashes in their hinge points tend to reduce the controllability in most cases and in more serious cases, these elements generate flutter. The number hinge points should be proportional to the control surface wingspan and the aerodynamic loads acting on this.

**This item is extremely important! In former editions of AeroDesign, there were aircraft crashes caused by problems related to backlashes in the surface links, attachments incompatible with the dimension of the surfaces, and flutter. This is, above all, a safety measure that should be taken very seriously.**

**Ensuring the structural rigidity of the control surfaces, especially in the case of the aircraft in the Open Class, where they usually are larger in size, is also an extremely important aspect that should be taken seriously and very carefully studied! These aspects will be required during the inspection visit of the aircraft.**

**We do not recommend for the aircraft in the Open Class that the control surfaces with large areas or large wingspans be made only as a flat sheet of plywood, even if they have more than one actuator (or servo) to move them.**

### 3.7.12. Servo Sizing

Analyses and/or tests should be presented in the Project Report, showing that the servos used on the aircraft are of adequate size and are able to handle, or are greater than, within a certain margin, the aerodynamic loads to which the airplane will be subjected during the flight.

If necessary, we recommend using more than one actuator (or servo) per surface, especially if they have a large wingspan and marginal torsion stiffness.

We recommend that special attention be given to all of the elements of the servos, such as, gearings and the joint between the “servo arm” and its “servo axis”. Low quality components could break, causing the loss of the torque transmitter element, resulting in a “moment equal zero” or, in other words, loss of control.

### 3.7.13. Maximum Eligible Weight

Aircraft of the Open Class may not have a total weight (empty weight + maximum load + fuel weight) of more than 35 kg (77.16 lb.).

It is the team’s responsibility to respect this maximum limit. If, after the flight, it is found that the weight of the aircraft, plus the load carried (PV + CP) exceed this limit, the flight will be invalidated and the aircraft may even be disqualified.

PV means Empty Weight (or Peso Vazio) and CP means Total Payload (or Carga Paga). In this case the fuel weight is part of the empty weight.

## 3.8. Takeoff Distance – Open Class

### 3.8.1. Takeoff Distance

The takeoff distance for the aircraft in the Open Class is no more than 61 meters (200 feet), that is, the aircraft must takeoff within this maximum distance.

The “Segmented Runway Concept” is NOT applied in the Open Class.

For more details, consult “Operational Procedures SAE AeroDesign 2008”, to be released, possibly, by March or April 2008.

### 3.8.2. Important Operational Aspects – Open Class

Since the aircraft in the Open Class can achieve a maximum weight of up to 35 kg, which characterizes them as “unmanned aircraft”, several items regarding takeoff should be taken into consideration.

- The takeoff should always begin, whatever the direction, on the strip that divides the two 61-meter runways, that is, near the middle of the “inhabited” region of the layout. After the beginning of the takeoff run, the aircraft must be moved away from the area where the crowd and the competitors are located.
- The takeoff should be as gradual as possible. The pilot should “control the angle of climb until it is away from the area where the crowd and the competitors are located. Only after getting away from this area can the aircraft truly gain altitude.

For more information about all of the operational details involving the aircraft in the Open Class, consult “Operational Procedures SAE AeroDesign 2008”, to be released, possibly, by March 2008.

### 3.9. Scoring – Open Class

#### 3.9.1. Payload Ratio

The airplanes of the Open Class will be given points, as follows:

Payload Ratio (or Razão de carga paga (RCP))

$$RCP = \frac{CP}{CP + PV}$$

where:

- CP is the total payload (“useful load”) – **in kg**
- PV is the aircraft empty weight – **in kg**

Score:

$$Points = \frac{CP}{100} \times [500 - abs(14 - 2,2 \cdot PV)^{2,6}] \times [RCP]^2$$

#### 3.9.2. Accuracy

Additional points will be added for the Open and Regular Classes based on the exactness of the “useful load” prediction. The score resulting from the accuracy of the estimated “useful load” is calculated according to the following formula, with the weights of the “predicted useful load” and “real useful load” expressed in kilograms (kg):

$$Points: [30 - 10 \times abs (Predicted Useful Load - Real Useful Load)^{1,5}]$$

and as long as the expression is a positive value. Otherwise, the score will be equal to zero (0).

In 2008, the maximum score for accuracy will be 30 points.

For the aircraft in the Open Class the “Segmented Runway Concept” will not be used and, therefore, the payload prediction graph should have only one curve valid for the takeoff within 61 meters (200 feet). See Appendix 6.2, page 73.

#### 3.9.3. “Quick Payload Removal” (only for Regular Class)

For the Open Class, in 2008, there will be no additional points for the time for removing the payload.

**This item is valid only for aircraft in the Regular Class.**

### 3.9.4. Empty Weight Flight Bonus – Bonus

The aircraft in the Open Class that are able to take one complete flight without the “payload group” (empty cargo bay or without the “payload assembly section” and payload plates) will receive a bonus of **ten (10) points**.

A complete flight is one where the aircraft takes off, takes the standard flight path (360° curve) and lands safely. The landing may be, in this case, in the same direction as the takeoff or in the opposite direction.

**The empty flight may only be taken after the CG of the empty aircraft has been checked by the judges and/or authorized safety inspectors.**

No additional balance weights will be authorized to correct the Center of Gravity (CG) of the aircraft, under the condition that the cargo bay is totally empty (without payload and “payload assembly section”).

The correct CG for performing the empty flight MUST be an inherent item of the project developed by the team.

We highly recommend that the teams that choose this bonus explain in the Report all of the project aspects observed, so that the aircraft is able to fly empty (without payload and “payload assembly section”).

## **4. Mission Requirements – Regular and Open Classes**

### **4.1. Flight Competition**

In order to participate in the Flight Competition, the team must have met all of the requirements of the Design Competition, that is, sent the Reports, plans and graph, and given the oral presentation.

#### **4.1.1. Safety Inspections**

The airplane must go through a safety inspection before each flight. The safety inspection does not penalize by taking away points, but it could keep the team from flying in any round, if the airplane is not in the required condition.

**Note:** So that the safety inspections are quick, allowing more flights to take place, a list with several requirements and with good safety practices will be issued in good time. For a complete visualization of these items, as well as the preliminary checklist to be used for the inspections, consult “Regulations and Good Safety Practices – SAE AeroDesign 2008”.

The safety evaluation will consist of the items on the safety checklist, but other items may also be checked, according to the situation. If the inspectors feel that the airplane is not safe for flight, due to not complying with the items on the checklist, the flight may not be authorized until all of the required items have been met.

**It is prohibited to have:**

- Metal propeller
- Repaired propeller
- Improperly mounted engine
- Wings with sharp or thin leading edges
- Pointed spinner
- Balance weight or any heavy part not appropriately fastened to the airplane structure.
- Radio equipment that is not protected against vibrations or interference.

Safety corrections are permitted, but may not interfere with the flight order and may not be made via radio, if this upsets the flight order (if the radio frequency coincides with that of an airplane preparing for flight).

These corrections must comply with the requirements made by the inspectors, regarding modifying the airplane during the Competition.

After correcting the problems found during the safety inspection, the team must wait to be called for a later flight round, present themselves, and show the safety inspector the modification or repair that was made.

Bad linkages, backlashes or lack of adequate structural stiffness in the controls are sufficient reason to keep the aircraft from flying.

Only small repairs can be made in the Safety Inspection Tent, that is, these repairs must not take (as a point of reference) more than five (5) minutes to be performed.

If the airplane should show, in flight, that it is not adequately controllable or that it has structural problems, it can be prohibited from flying in the following flight rounds.

#### 4.1.2. Weighing Process

The airplanes of the Open and Regular Classes will weigh the empty aircraft only after the valid flights and after removing the whole payload group from the cargo bay.

**No team will be authorized to weigh the aircraft and/or the payload, except during the normal sequence of the flight round.**

#### 4.1.3. Aircraft Maximum Dimensions and Cargo Bay Verification

The airplanes of the Regular Class whose flights are valid, may be subjected, once again, to the dimensional inspection process, as described in Sections 2.2.1 and 2.2.2.

So that the aircraft in the Regular Class are not penalized, the sum of their main dimensions (Sections 2.2.1., 2.2.2., and 2.2.3.) must remain between 6.30 meters and 6.35 meters. Dimensions below 6.30 meters or greater than 6.35 meters, will be penalized, as provided for in Section 2.2.3., page 18.

It is the responsibility of the team to comply with the construction tolerances so that the aircraft is presented within the maximum and minimum tolerances set by the Regulations (Regular Class, Section 2.2.3.).

The cargo bay (Regular Class) will also have its volume checked and the block of wood used for this check should not be inserted by applying excessive force, that is, the adjustment should be "sliding" (see item 2.5, page 20).

#### 4.1.4. Qualifications

In order to participate in the Flight Competition, the team must meet all of the requirements of the Design Competition and have previously flown the airplane. The team must turn in, on the first day of the event, during the reception of the teams, a declaration by the academic adviser of the team, which is also signed by the head of the school (or representative), stating that the airplane, in the condition in which it was taken to the Competition (after any significant repairs have been made) flew prior to the Competition (Appendix 6.9). **No declaration made by members of the team or other students will be accepted.**

The airplane, during the classification rounds, must carry a payload of at least [3.5 kg \(Regular Class\)](#) or [8 kg \(Open Class\)](#). This qualifying flight may be held with any one of the three classification rounds on the first day (or by the second day) of Flight Competition and will be eliminatory, that is, the teams will have no more than three chances, and those who are classified during one of these chances will only fly again during the Competition flight rounds. After the three classification rounds, on the following day(s) (determined by the number of remaining teams), the flights will be held only for the Competition rounds.

If it is impossible to hold the three classification rounds on the first day of Competition, they will be finished by no later than the end of the second day of flights. The third day will be specifically for the Competition rounds where only the teams classified during one of the three classification rounds will be eligible to participate. The ideal is that the classification rounds take no more than 50% of the time of the Flight Competition, that is, one day and a half. Each team will have three chances, at most, to classify. If the team is not able to classify in its three chances, it will not be able to continue in the Competition. If it is able to classify during the first classification rounds, the team will only fly, again, in the fourth round (or first Competition rounds). The same is true for those that classify during the second classification rounds, that is, they will not fly in the third classification round. These

three classification rounds are dedicated exclusively to providing the teams with a maximum of three chances to classify.

The qualifying flight will be scored.

**Note:** Since 2006, the Flight Competition has always consisted of three classification flight rounds and the maximum possible number of Competition flight rounds.

#### 4.1.5. Standard Flight (totally valid flight)

The airplane must take off in the Section of the runway marked according to its Class (see item 2.8.2., page 26, for the Regular Class, and item 3.8.1., page 39, for the Open Class). The width of the runway is generally 10 meters, but it will be made very clear during the Competition.

The aircraft taking off within the maximum distance set for the Class (Regular or Open) should take at least one lap of 360 degrees and, then, land. The starting position of the airplane is with the main landing gear on the starting line of the runway. The airplane must take off within the maximum distance set, or the attempt will be invalidated.

There is no limit of the number of laps the airplane can take before landing, as long as it does not run out of fuel or go outside of the air space set before the Competition.

More details will be issued, in good time, in a specific document: “Operational Procedures – SAE AeroDesign 2008”. It is extremely important, as already mentioned, to read this document.

**Note:** The available air space will be that which is regulated by the “Operational Procedures” and is based on safety rules for “model airplane” flight. These must be strictly followed. A flight outside of the established limits may disqualify a team. A definition of the “flight box” can be found in the “Operational Procedures” and will also be presented during the briefing before the Flight Competition.

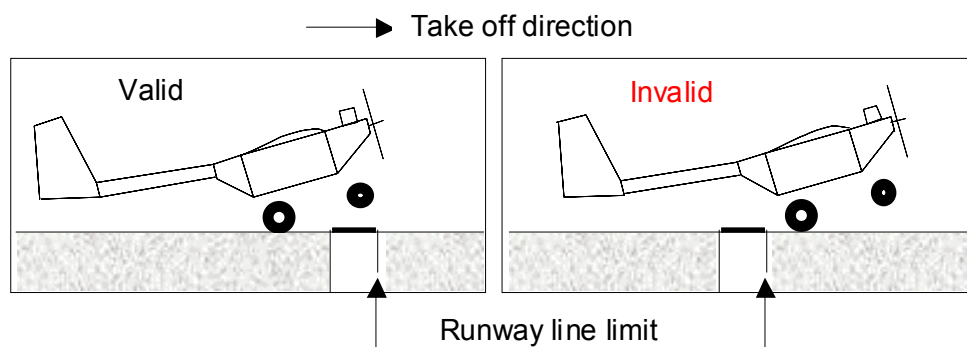

The takeoff lines will be marked by the runway judges of the Technical Committee. These lines are the official flight takeoff points, whether they are precisely 61 meters or 30.5 meters. The width of the stripe is the “*inaccuracy zone*”. The figures, above, show the rear wheels of the landing gear (main gear, in the case of tricycle, and tail wheel, in the case of conventional landing gear) at the last instant on the ground and after the airplane has completely taken off (being lifted by the wings). The white stripe is the limit for the takeoff.



#### 4.1.6. Landing

The airplane must land within the area designated as the landing zone, which is 122 meters long. Touches and go-arounds will not be permitted. A crash invalidates the attempt. A valid landing is established as touching down within the established 122 meters, rolling and stopping (with no length limit). The width allowed for the touch down, run and stop will be shown in the “Operational Procedures” and also at the time of the Competition. The first touch of the airplane on the ground must be within the designated landing zone, but rolling to a stop may go beyond the limits of the runway. If the airplane goes beyond the longitudinal limit of the landing zone, it must do it rolling, that is, with at least one of the wheels touching the ground.

The landing will be considered valid according to the criteria established, above. Nevertheless, bonus points will be given to the teams that are able to completely stop their aircraft within the area marked on the runway, that is, that do not go beyond the longitudinal and lateral limits of the runway at any time during the landing, until the airplane is stopped.

For each landing that meets this requirement, **bonus points** will be given, according to the following equation.

$$Bonus = 0.25*EE*CP \quad \text{or} \quad Bonus = 0.25*(CP)^2 / PV$$

Where:

EE = CP/ PV = Structural Efficiency Factor

CP = Payload (kg)

PV = Aircraft Empty Weight (kg)

The points which are considered in the final score obtained by the team will only be those points related to the best round. **This bonus WILL NOT BE CUMULATIVE.**

The bonus is valid for the two Classes (Regular and Open), therefore, for each round, each team has a chance to receive bonus points, if the flight is completely valid and the restriction, above, is met.

Hard landings, zigzag landings within runway lateral limits, or bumpy landings, are allowed, but not recommended.

The criteria for evaluating whether the landing was valid (or within the marked landing zone) and worthy of bonus points, are established as:

- If after the stop, 50% of the airplane is still within the marked landing zone, the flight is valid.
- If after the stop, 50% of the airplane is outside of the established landing zone, the flight will not be valid and, therefore, has no right to bonus points.

The runway inspectors will make their judgments based on these criteria. The inspector’s word is final and irrevocable. In cases that are considered to be more critical, we recommend consulting the members of the Technical Committee, in order to come to a final decision.

Starting in 2007, a penalty was created that should be applied, at the discretion of the team, to validate the flight of an aircraft that has skidded off the side of the runway. For every “runway lateral escape”, the team that chooses to validate the flight will lose 20 points for every occurrence of this type. This “penalty” is cumulative, that means, an aircraft that “missed the runway lateral limits” two times throughout the entire Competition (if the team wants to validate these two flights) will lose 40 points, which will be discounted from the final score obtained by the team in the Competition.

All of the pertinent details of these landing items will be presented in “Operational Procedures – SAE AeroDesign 2008”.

#### 4.1.7. Airplane condition after landing

The airplane should take off and land with all of its parts, in order to receive points for the attempt. All of the parts must remain attached to the airplane for a valid landing, except the propeller, that could be broken upon contact with the ground. The airplane should land with the same parts with which it took off, therefore, it is not allowed to discard parts upon takeoff or during any other moment of the flight. **Broken parts, even if they remain attached to the aircraft, invalidate the flight**, that is, elements that totally break and remain “connected” to the structure of the aircraft via cables, NO LONGER ENSURE THE VALIDATION OF THE FLIGHT.

Losing a wheel (entirely or partially), a shaft, or any part that has a function and that changes the original aircraft or that affect, or do not facilitate a later flight, without the need of repair, invalidates that flight. No discussion will be accepted regarding the possibility of a later flight, without any of the elements described in the statement, above. For example: losing any part of the wheel, like a tire (or O-ring) is considered a no-go item for the next takeoff, because it affects the safety of the run and, consequently, should be repaired.

Slivers of wood (from a wing tip, for example), small pieces of the airplane’s skin (Ex.: Monokote), or any other small element that definitely does not change the original design and/or compromise the structural integrity of the aircraft and also does not affect the safety of a next flight may be considered as elements that do not invalidate the flight. Broken stay wires or diagonal braces, as long as they are connected to the aircraft, might not invalidate the flight. This is considered to be the only exception to the rule, above. The final word on the invalidation of the flight, or not, in a situation of this type, will always be made by a member of the Technical Committee (yellow shirts). It could be a Runway Judge or a Judge that is near the event which has occurred. This decision is final and irrevocable.

More details about these items may be found in the “Operational Procedures – SAE AeroDesign 2008”. All of the items referring to this subject, which will be available in this document, will be considered as updates of this Section 4.1.7., and will be mandatory in nature.

After the complete stop of the airplane, the team captain (or a representative that is in the area, preparing for the flight) may not go outside of the area marked for the flight until the airplane has completely stopped. After the complete stop, the captain of the team may not come any closer than two (2) meters of the airplane until the runway inspector has arrived at the airplane and checked its integrity. If this rule is not obeyed, the flight will be invalidated.

#### 4.1.8. Alterations and Repairs

The original project of the airplane, as presented in the Design Competition, can be repaired during the course of the Competition. However, the airplane must arrive at the end with its original parts (or substituted by replacement parts identical to the originals), with the exception of the propeller, engine<sup>(1)</sup>, servos, radios and components of the landing gear that can be substituted or changed at any time on the ground.

**(1): The engines of the five (5) first places in the Competition (Regular Class) will be disassembled, reviewed and checked for changes, after the Competition.**

The substituted parts, mentioned above, must be identical to the originals, except for the propeller. Any change in relation to the original project should be informed as set forth in Section 1.9.1.

For the Open Class, it is **EXPRESSLY FORBIDDEN TO REPAIR PARTS OR SETS OF PRIMARY STRUCTURES**, such as:

- Wing spar
- Boom or tail boom of the fuselage
- Horizontal Tail Spar
- Among others, according to the aircraft.

If the aircraft breaks down, its participation will only be authorized in the next rounds, if the broken part or group (a wing, for example) is substituted for another identical one and after the aircraft is examined in great detail. The coordinator of the safety inspectors **MUST** be informed of the substitution or repair of any component of the aircraft. Not sharing this information could result in a penalty for the team.

Changes may be made only with the permission of the judges, to handle the changes required by them during a safety inspection.

NOTE 1: Any change (whether for repair or not) in relation to the original project should be declared and authorized and, eventually, it will be subject to the penalties set by the judges.

NOTE 2: Aircraft of the Open Class approved by the “Project Validation and Follow-up Process” may not modify primary structural parts under any circumstances, except when the modification has been requested or approved by a judge of the Competition and/or experienced safety inspector in the Open Class. Ex.: a wing spar or a torsion box of a wing cannot have its design modified without it being requested, or without the prior authorization of a Competition judge.

The addition of skin material, adhesive tape, glue, small screws or rivets, and internal structural components (or reinforcing) **for repairs** are not considered to be alterations in the project.

**Each team may take no more than one reserve airplane.**

**The substitution of parts that are identical to the originals for any part of the airplane will be permitted. This allows the team to take a reserve airplane to the Competition. Only ONE (1) reserve airplane is permitted. The purpose of this limitation is to lessen the influence of the availability of financial resources of each team on the results of the Competition.**

## **4.1.9. Additional Flight Considerations**

### **4.1.9.1. Flight Order**

The flight order for the Competition is based on the total points accumulated in the Design Competition or in the previous rounds. The team with the lowest score flies first. If it is not ready to fly, it should await the next round.

After the call to prepare for the flight, the team will have five (5) minutes to go for the safety inspection and to fill up with fuel. If it does not show up, it will lose the round. If the team does not pass the safety inspection, it will lose its turn in the round.

The team must go for the inspection with the payload group completely assembled and secure inside the cargo bay. Using the Competition scale will not be allowed

under any circumstance. The scale will be for the exclusive use of the inspectors. It is not appropriate, from an operational standpoint to make exceptions for any team.

If the flight was valid, the weighing will be done after the landing, in the inspection and weighing area. The team will remove the payload in the presence of an inspector who will weigh it and inform the team of the actual weight. The dimensions will be checked and the volume of the cargo bay will be calculated thereafter.

The team may choose to publicize the weight carried during the round. The inspectors must be informed of the fact, in advance, by a member of the team, before placing the payload on the scale.

**NOTE:** It is the team's responsibility to pay close attention to the call to prepare for flight.

In order to avoid confusion, flight positions will not be allowed to be changed, except when guided by a member of the Technical Committee (yellow shirt).

The flight order may be changed for each round, according to the resulting total score of each round, if there are logistical conditions for this.

#### 4.1.9.2. Takeoff Time

Each team of the Regular Class will have three (3) minutes for the takeoff, from the time they are called. In the Open Class, the time will be five (5) minutes. Within the time established for each Class, the team may make up to three (3) takeoff attempts. If the team is not ready for the flight when called, it will lose its turn, and will have to await the next round to fly.

Eventual interferences may occur (approaching aircraft), causing the attempt to be interrupted. A new countdown will begin after the runway is free.

More details will be published in "*Operational Procedures – SAE AeroDesign 2008*".

#### 4.1.9.3. "Useful Load"

The weight of the "useful load" (or "payload group") and its balanced distribution (required only for Regular Class) (see Section 2.5.1 and Appendix 6.1.C) will be recorded and checked by the inspectors after each valid flight. Furthermore, only for the Regular Class, the inspectors will time the opening of the compartment for the "quick payload removal", giving bonus points, when applicable, as described in Section 2.9.4.

**For 2008, the time considered for the final score, with reference to the bonus for the "quick payload removal", will be that of the best round. The fastest time among all of the attempts will no longer be considered in the final score, but, rather, the time of the best round.**

**NOTE: opening the cargo bay of the airplane without the authorization of one of the judges will invalidate the flight.**

#### 4.1.9.4. Fuel (Regular Class)

The fuel supplied by the organizers will be the only one used during the Competition. The refueling will be done only by the fuel inspectors.

In the previous editions of the Competition, the fuel (Byron, with 10% nitromethane) was used because of its high quality. The brand will be the first option of the Technical Committee, and will only NOT be used, if it is not available on the market, or if it is impossible to pay the cost of this fuel.

The removal of the fuel before weighing and determining the EE factor may be done by the team, but **ONLY WHEN ACCOMPANIED BY THE INSPECTOR RESPONSIBLE FOR THE AIRCRAFT. IT IS PROHIBITED TO REMOVE THE FUEL WITHOUT BEING PROPERLY ACCOMPANIED.** This procedure seeks to facilitate the logistics of the Competition, by avoiding that the aircraft return to the fuel stand for removing the fuel, as well as handling fuel in areas not reserved for that purpose.

#### **4.1.9.5. Test Flight**

If possible and truly necessary, test flights may be required by the Technical Committee. Fuel will not be supplied for the test flights or for breaking in the engines. The flight will be accompanied by an inspector or a judge.

#### **4.1.10. Final Round**

The main objective of the Technical Committee, when preparing the procedures for the SAE AeroDesign Competition, is to see that the Competition always has as large a number of rounds as possible. In all, there are three Qualifying Rounds and as many Competition Rounds as possible, when only the qualified aircraft participate. Qualified aircraft have made a complete and successful flight, with at least, the minimum payload defined above (Section 4.1.4 - Qualifications, page 63).

However, it is not always possible to make a complete final round, that is, with all of the classified teams. Therefore, in order to guarantee a maximum level of competitiveness among the leading teams, there could be a round for the finalists. The number of teams allowed in this round will be determined by the organizers of the Competition, based on the accumulated points, so that no team that has a chance to win the Competition is left out.

More details about how the number of teams is established for the final round will be published in "Operational Procedures – SAE AeroDesign 2008".

### **4.2. Scoring**

Preliminary scores will be released during the awards ceremony, on the last day of the Competition. The final score will be published on the site of SAE BRASIL and sent to the teams, up to 10 days after the Competition.

#### **4.2.1. Overall Score**

The overall score will be calculated, as follows:

**Total Points = Design Competition Points + Flight Competition Points + Applicable Bonuses – Penalties**

##### **4.2.1.1. Design Competition**

In 2008, the Design Competition will be scored according to the following criteria:

- **Report, Plans (or Drawings) and Payload prediction plot: 165 points**
- **Oral Presentation: 35 points**

##### **4.2.1.2. Flight Competition**

The number of points given to a team for the total payload (or "useful load") carried will be in line with what is established in Sections 2.9.1., page 27, and 3.9.1., page 40 (Regular and Open Classes, respectively).

The bonus points for "quick payload removal" (exclusively for the Regular Class) will be calculated according to the equation shown in Section 2.9.4., page 29.

**ATTENTION:** The points for the “useful load” carried (Open and Regular Classes), payload prediction accuracy (Open and Regular Classes), Structural Efficiency Factor (Regular Class), and Payload Factor (Open Class), landing bonus (Regular and Open Classes), and a bonus for “quick payload removal” (Regular Class) will be added according to each round, and the highest total (or best round) will be considered for the final score.

The bonus points for the “minimum volume box” that holds the disassembled aircraft will be determined in accordance with Section 2.9.5., page 29, and are valid only for the 30 smallest volumes.

The bonus points for each valid landing, within the runway limits, will be given in accordance with the restrictions established in Section 4.1.6., page 45.

## 4.3. Penalty Scenarios

### 4.3.1. Penalties

Some of the possible penalties are presented in the following table, but other penalties could occur, on a case-by-case basis.

The penalties are divided by subject

<b>1 – Oral Presentation</b>	
<b>Description</b>	<b>Penalty</b>
Not having the airplane assembled and <b>complete</b> for the oral presentation (or not available for the judges, in the case of the Open Class, as per Section 5.1.5).	20 points
Delayed oral presentation	2 points/minute
Interruption by professors and advisers during the oral presentation	5 points
Undue interruption (without presentation) by other members of the team during the oral presentation	2 points

<b>2 – Aircraft non-conformity</b>	
<b>Description</b>	<b>Penalty</b>
Substitution of different parts of the project without giving notice	up to 10 points
Repairing primary parts without giving due notice – Regular Class	up to 20 points
Repairing primary parts – Open Class	up to 20 points
Lack of the <u>three views</u> clearly showing the means to be used for the dimensional inspection. Sections 2.2.1., 2.2.2. and 2.2.3., and Appendix 6.4C.	10 points
Absence of the aircraft (Regular Class) for the first dimensional inspection (day of the oral presentations) (according to Section 2.2.2)	20 points
Aircraft with dimensions not complying with the specifications in Sections 2.2.1 and 2.2.3.	Penalty according to item 2.2.3
<u>Late delivery of the complete Report at the correct address</u>	<u>5 points/day</u>
Not sending the complete video of aircraft flight (Open Class), as per Section 3.7.6.	Flight prohibited in the Competition area
Not presenting the video of aircraft flight in the Regular Class, if it has been required by the Organizing Committee, as per Section 2.7.9.	5 points
Dimensions of the cargo bay not complying with the specifications (including interference by fasteners, cables, or other elements)	Invalidation of the flight, or even the disqualification of the team

<b>3 – Operational Items</b>	
<b>Description</b>	<b>Penalty</b>
<u>Not turning in all of the radios (including the reserves) at the Radio Stand, by 7:30 a.m., on the three days of the Flight Competition.</u>	20 points/day
Project alteration	Case-by-case
Nonconformity with the project	Case-by-case
First flight in the Competition area	Not allowed
Disrespect of the established air space	Open for disqualification
Unfounded protests	Max 25 points
Infringement of safety rules	Disqualification
Unexpected unsafe attitudes	According to case
Delay in delivering the required documents at the reception desk by 12 noon on the Friday immediately preceding the beginning of the Flight Competition (Declaration that the airplane has already flown, Statement of Agreement with the “Operational Procedures”, ABA membership card, radio frequency, Form for changing the pilot, when applicable).	10 points
<b><u>Note: the lack of any of these documents keeps the team from flying, until the documentation has been provided.</u></b>	
Disrespect / disobedience of judges and inspectors.	Minimum of 10 points, or even disqualification Evaluated according to the case.

<b>4 – Report - Sending</b>	
<b>Description</b>	<b>Penalty</b>
<u>Delay in delivering the complete Report to the correct address</u>	5 points/day
Sending to the wrong address	10 points

<b>5 – Report - Format</b>	
<b>Description</b>	<b>Penalty</b>
Report not bound (spiral binding preferred)	2 points
Number of excess pages	2 points/page
Incomplete cover (Lacking team number, name, and name of the school)	1 point
Margins not complying with instructions	2 points maximum
Format not as specified (different from A4)	2 points
Not using the required font	1 - 3 points
Line spacing not used as specified	5 points
Lacking a copy of the Liability Release bound with the Report (see figure of the structure of the Report in Chapter 5).	3 points
Lacking one or more of the five copies of the Report.	10 points/copy
Lack of technical specifications and engine modifications (Open Class)	10 points

<b>6 – Prediction Payload Plot - Format</b>	
<b>Description</b>	<b>Penalty</b>
Graph not bound with the Report	2 points
Lack of team name, number and name of the school on the graph	1 point
Lack of indication of <i>Sections</i> ( <i>Section 1</i> and <i>2</i> ) on the prediction payload plots, as per item 5.1.5., page 45. Only aircraft of the Regular Class.	Up to 5 points
Lack of a linear equation on the graph	5 points
Lack of a line on the graph	1 point

<b>7 – Plans - Format</b>	
<b>Description</b>	<b>Penalty</b>
Lack of a key (name of team, school) on the plans	1 point
Lack of a Dimensional Inspection plan (Section 2.2.2) Aircraft in the Regular Class.	4 points maximum
Lack of the “3 views” plan	3 points
Lack of information boxes on the “3 views”, or on the Dimensional Inspection plan, or on the “Minimum Volume Box” plan. The presentation of these tables is always very important.	2 points
Lack of information (dimensions or numbers) on the Dimensional Inspection plans.	Up to 5 points
Plans not complying with the specified format (A3 or A2)	2 points
Plans not bound with the Report	0.2 point/plan

The strict manner with which the AeroDesign Brazil Competition is organized, reflected especially in the penalties, should not be interpreted as persecution, or a desire to jeopardize a team or school. Rather, it should be interpreted for its educational purpose, assisting students to reflect on failures, how to correct them and, especially, how to prevent them. The penalties are rigorous, when necessary, in order to raise the level of the Competition, and they also give the Competition not only an educational character in the technical area, but also in the organizational area, in all senses.

The penalties reflect the reality of the world, outside of the school, in the sense that slight carelessness, errors of interpretation, lack of organization, lack of good team work, and lack of group coordination sometimes cause big damages and are decisive for the success or failure of a project of any type. At this time, the adviser plays a basic role, tracing parallels with professional realities, whether academic, or corporate, and especially in the aeronautics field, where apparently simple carelessness can put lives at risk and/or cause great financial loss.

#### **4.4. Overall Conduct and Safety**

In the case of unsportsmanlike conduct, the team could initially receive a verbal warning, or in writing, from the Technical Committee. A second violation will result in the disqualification of the team.

The organizers, judges or inspectors might prohibit any flight by any airplane considered to be unsafe, until the conditions are changed and the airplane has been minutely reinspected by the judges or inspectors.



The safety rules for the Flight Competition will be presented to all of the participants throughout the year and before the beginning of the Competition. However, any attitude that the organizers consider to be unsafe, even if not provided for in the safety rules, will be considered as unsafe.

As for the operational aspects, cited above, the Technical and Organizing Committee is preparing an updating of the "Operational Procedures – SAE AeroDesign 2008", in which the following items will be inserted *a priori*, not necessarily in this order:

- Important aspects regarding the layout
- Rules for the circulation of the aircraft
- Description the procedures used in the Competition
  - Check of the "minimum volume box"
  - Dimensional inspection
  - "Quick payload removal".
  - Weighing the total payload and the empty aircraft
  - others
- Flight procedures
- Partial and final scores
- Plus many others...

**The deliberate violation of any safety rule may result in the immediate elimination of the team.**

**Arguing with or disobeying any judge could result in a warning or even the elimination of the team. Members of the Technical Committee are prepared and ready to handle any question (or problem) that may be experienced by a team (or team member).**

**Remember that all of the judges and inspectors are volunteers and are making every effort to guarantee a successful Competition for ALL involved: Teams, Sponsors, the Public, etc.. We count on the collaboration of everyone to guarantee the success of the 10<sup>th</sup> SAE AeroDesign Competition.**

**It will NOT be permitted, under any circumstance, to SMOKE in the Competition areas, due to the safety risks and health problems that can be caused. Smokers must use the areas RESERVED FOR SMOKERS. Those areas will be indicated on the diagram of the Competition. See "Operational Procedures – SAE AeroDesign 2008".**

**It will not be permitted to drink any alcoholic beverages or use any illegal chemical product on the premises of the Competition Area<sup>(1)</sup>. This rule is valid during the entire Competition, in any phase. Any violation of this rule may imply the immediate expulsion of all of the members of the teams from the same school, and not only of the team that violated the rule. This applies to the members of the teams and faculty advisors. The Organizing Committee of AeroDesign asks everyone to collaborate with these issues.**

**The organizers of the Competition reserve the right to alter the schedule, as well as to interpret the rules of the Competition, at any time, at its own discretion, for efficiently operating the event or the safety of the Competition. We expect the understanding of everyone, if this becomes necessary.**

#### 4.5. Notes

Any comments or questions regarding the rules must be sent to the Technical Committee of the AeroDesign Competition, as quickly as possible, to avoid misunderstandings about its purposes and intentions.

In this sense, contact must be made with Vanessa Viana, on the staff of the Central Offices of SAE BRASIL, in São Paulo, via E-mail: [vanessa.viana@saebrasil.org.br](mailto:vanessa.viana@saebrasil.org.br).

---

(1) The premises of the Competition (or Competition Area) are understood to be any and all places of the Layout/Diagram established for SAE AeroDesign Brazil (which is shown in “Operational Procedures”), as well as the entire CTA grounds (which is a military area). All commemorations (associated with the consumption of alcoholic beverages) are “permitted”, as long as they are held in appropriate places, off the premises of the Competition and, preferably, at times that do not interfere with the Competition.

## 5. General Rules – Report and Presentation

The SAE AeroDesign Competition is normally divided into two parts:

- 1 – Design Competition, and
- 2 – Flight Competition

In the Design Competition, the team will present its project, justifying the decisions made and the calculations used for the aircraft design and an estimate of the maximum “useful load” that can be transported.

The Flight Competition will determine which airplane carries the most weight, according to the rules described, above. The bonus for structural efficiency and landing within the limits of the runway will be established during the Flight Competition. The others will be applied separately, as the case may require.

### 5.1. Design Competition

The Design Competition is divided into four parts: Project Report, Plans, Payload Prediction Accuracy, and Oral Presentation.

In 2008, the total score of the Design Competition will be **200 points**.

Of this total, **165 points** will be given to an evaluation of the Report, plans and graph of the payload prediction. The score will be subdivided according to areas, as follows:

- Conceptual & Pre Design: 40 points (30 + 10: project and plans)
- Loads & Structures: 35 points (30 + 5: Report and plans)
- Aerodynamics: 30 points
- Performance: 30 points (25 + 5: Report and graph)
- Stability and Control: 30 points

The content and quality of the Report, plans and graph will be evaluated according to these points. Creativity and innovation will also be evaluated according to the case and within each of these disciplines.

The Oral Presentation is worth **35 points**.

#### 5.1.1. Design Report

Each team should deliver **five (5) copies of the Project Report and a CD with an electronic copy of the Report (in pdf format)**, detailing the methodology, calculations and results of the project **to the address in blue, described in Item 3, Part I, page III (third page after the Index)**.

The Report may contain:

1. Description and/or demonstration of the solutions adopted by the team to define the configuration chosen for the aircraft. It is important that the Conceptual and Preliminary Projects be very well founded.
2. Detailed description of the methodology for calculating and analyzing the forces acting on the structure of the aircraft or the load prediction, for the later and correct development of the structural calculations of the aircraft.
3. Methods and results of the performance analysis, stability and control calculations, and aerodynamic calculations of the airplane.

4. Detailed description of the maximum “useful load” to be transported, according to altitude-density. This description will be complemented by a graph representing the estimated maximum “useful load” (or payload prediction), according to altitude-density (see Section 5.1.4., page 63).
5. Any dynamic analysis performed.
6. Any innovative or original idea of the project.

The Building Instructions of the aircraft should not be included in the Project Report.

The manner of building the aircraft can be visually explained in the plans.

Descriptions of innovative or unique techniques for building the aircraft and of the use of high technology materials may be included.

As for sending the CD containing an additional copy of the Report in pdf format, it is mandatory that it be sent along with the Reports (in the same mailing). Additional files can be recorded on the CD, if the team so wishes, but they are not necessarily a part of the evaluation process.

We suggest that in the Report package there be included a copy of the proof of mailing in a small envelope, to facilitate identifying the date on which the mailing was sent.

The Reports sent are considered to be confidential material by the Technical Committee, where access is guaranteed only to the judges of AeroDesign. This treatment will be even greater with the CDs sent.

An electronic copy of the Project Report will be used for evaluation only in special cases, that is, there will be no uncontrolled dissemination of the work done by the teams. The main objective of the CD is to record the work of the teams electronically, which is always important for preparing improvements in future Competitions and new rules.

It is the objective of the Technical Committee, for 2008, to return, during the Competition, at least three of the five copies of the Reports sent by the teams. Those copies will not necessarily be returned with comments or any opinion, in writing. They must be picked up in the Forum or at the Competition, itself.

The Technical Committee is studying some means of feedback, in writing, for the teams to do on a specific form. More explanation about this item will be given at the **3<sup>rd</sup> SAE AeroDesign Forum** to be held, possibly, in April 2008.

#### **Recommendation for facilitating the internal circulation of the Reports.**

In order to improve and facilitate the internal circulation of the Reports + CD, we suggest that they be sent only in plastic envelopes, especially with the mailings that contain the Reports of only one team.

The use of cardboard boxes is not recommended (except for International Teams), because they must be inspected for internal release, which makes it hard to begin the distribution work and the evaluation of the Reports.

### **5.1.1.1. Report format and limitations**

The Report must contain no more than 35 pages for the Regular Class and no more than 45 pages for the Open Class. This number of pages does not include a frontispiece (or cover), a copy of the Liability Release (whose bound presentation is MANDATORY in the Report, itself) and, if applicable, the document required in Section 1.8.2.

For the Open Class, the pages referring to information on the engine are not considered as pages of the Report (See Section 3.2., page 31).

The format of the Report must be: **double-spaced**, typed on A-4 paper, using the **Times New Roman** font, size 12 (with **Normal** spacing between letters). **The minimum margins must be: 2.5 cm on the left, 1.25 cm at the top, 1.25 on the right, and 1.25 cm at the bottom.** The Report must be bound so as not to have loose pages. Preferably, the binding should be spiral. Glued or pressure-sealed bindings usually present problems after the handling of the Reports.

We highly recommend that the plans be folded appropriately (according to ABNT or ISO standards) so that they can be bound together with the pages of the Report, without their edges exceeding the size of a page of A-4 paper.

**Each Report must be marked with the name and number of the team, and the school on the first “visible page” of the Report (frontispiece or cover) in a clear and easily visible manner. We recommend that the name and number of the team be more in the middle of the cover, because this position is quickly seen and facilitates consultation, when there is a need for a quick check of a large number, or groups, of Reports.**

A sample of a cover (or frontispiece) of the Report is shown in the drawing, below. This standard is not mandatory, but merely a recommendation. We ask that you pay special attention to the placement of the name and number of the team.

The diagram shows a rectangular layout for a report cover with a light blue background. A vertical dashed line runs down the center, and a horizontal dashed line crosses it. The text is arranged as follows:

- Top section (above the horizontal line):
  - School Name
  - College Course
- Middle section (between the horizontal and vertical lines):
  - Title
- Bottom section (below the horizontal line):
  - Team Name
  - No. 00
  - Team Member Names
  - Faculty Advisor Name
  - City / State / Country
  - Month 2008

Clearly identifying the Reports is indispensable for the Technical Committee to be able to handle them more quickly and without error. The work of receiving, distributing and evaluating the Reports is more efficient when they are well identified and well bound.

The Report will be evaluated for its technical content, methods used, creativity, project innovation, logical organization, clarity.

**The Reports can be done in Portuguese, English or Spanish.** For the foreign teams, it is preferable to have Reports in English.

The maximum number of pages allowed are: 35 pages for the Regular Class and 45 pages for the Open Class. You should never confuse this limitation with the last number of the numbered pages. Therefore, if the team decides to number part of the Report with Roman numerals, or not to number a page, those pages will also be counted in the maximum number of pages allowed for each Class.

The frontispiece (or cover), where the school and the team are identified, is not counted as a page of the Report.

It is important to pay close attention and not try to “economize” on elements that facilitate an understanding of the Report, like the Index, for example. The list of symbols and abbreviations and, especially, the bibliographical references are also very important. This helps a lot to have a better understanding of the research done by the students.

### 5.1.1.2. Attachments and Appendixes

Appendixes and attachments of any type are not allowed in the Report (calculations, photos, texts, etc.).

For the Open Class, only, the presentation is mandatory in an attachment referring to the documentation of the manufacturer of the engine, indicating the engine displacement and changes made in the engines, if that is the case.

For the Open Class, any additional documents that the team wants to send can be sent along with the Follow-up Report, but they will not be a part of the Project Evaluation.

Sending a large amount of information regarding the aircraft project of the Open Class is even recommended by the Technical Committee, but will not be accepted if bound with the Project Report (sent in July).

### 5.1.2. Plans

#### 5.1.2.1. Plans – Regular Class – General Information

Each team must turn in five detailed copies of the plans of the airplane and one (or two) more plans, as cited, below.

The basic plans consist of five (5) pages on A3 paper, printed only on one side, folded adequately (according to ABNT or ISO standards for A-3 paper), which must be added and bound with the Report so that the judges can analyze them by merely opening them, without removing them from the Report.

A page should contain the drawing in three views, in standard aeronautical format, that is, view of the airplane from above in the upper left side of the page, with the nose pointing down; below this, a frontal view of the airplane, and the side view on its right, with the nose of the airplane toward the left side of the page (see Appendix 6.3). At the top of the side view there must be a table with a summary of the data of the airplane with AT LEAST the information requested in the example of Appendix 6.3. The units of measurement should always be in the metric system, as in the sample table. As a suggestion, the other four basic plans may follow the format of the drawings (or plans) presented in any model airplane magazine.

At least one of the plans must show the cargo bay, with its dimensions, as well as the devices for fastening the payload, and the “payload assembly section” to the structure of the aircraft.

All of the pages of the plans should be marked with the name of the school, name and number of the team, in a key in the lower right-hand corner.

There is no mandatory order for binding the plans, but to facilitate consultation, we suggest that the 3-view plans for the two Classes (Regular and Open) (Appendix 6.3, page 74) be first (about the structure of the Report see Section 5.1.7. page 65, and Appendix 6.10, page 85).

For the Regular Class, only, we suggest that the last plan be the one to be used for the dimensional inspection (Appendix 6.4C, page 79). If the team chooses the bonus of the “minimum volume box” (Appendix 6.5, page 80), we recommend that the plan be just before the page of the Dimensional Inspection.

The plans are normally evaluated by the following criteria:

- Clarity and neatness;
- Details of the components of the aircraft;
- Possibility of reproducing the aircraft based on the plans;
- Use of technical standards to represent the aircraft and its subsets (quotes, cross-sections, views, details, and others).

The teams can make colored plans, as long as the type of colors used do not affect the clarity or the interpretation of the drawings. Excessively colorful plans are not necessarily easier to understand than plans done in black and white.

The use of colors should facilitate the interpretation of the drawing. It is always good to keep this in mind.

### **5.1.2.2. Additional Plans – Information for the Dimensional Inspection**

In order to facilitate the procedure for the dimensional inspection of the aircraft and avoid eventual errors in interpreting the main aircraft dimensions (L, H, B<sub>1</sub> to B<sub>n</sub>), an A3 page must be sent with the three views of the aircraft, according to the same standard already established, but **ONLY** with the main dimensions, defined above, and with the designation of the “groups of aerodynamic surfaces” on the side view. (See sample plan in Appendix 6.4C, page 79).

A copy of these plans must be bound with each copy of the Report. We recommend, as already cited, that these plans be bound in the Report as the last page (or plan 7).

A table, as shown in the figure, below, must be presented in the upper right-hand corner of these plans. The information shown in this table is mandatory. The table can, if that is the case, contain additional information, if the team so desires.

Team Number / Team Name		
Maximum Dimensions (insert values in mm)		
L	Maximum Length (mm)	
H	Maximum Height (mm)	
B <sub>1</sub>	Biggest Span. 'Group 1' (mm)	
B <sub>2</sub>	Biggest Span. 'Group 2' (mm)	
...	...	
B <sub>n</sub>	Biggest Span. 'Group 'n''(mm)	
Dimensions Total Sum (mm)		▶

ITEM	Area in cm <sup>2</sup>
Wing Area (cm <sup>2</sup> )	
Hor. Emp. Area (cm <sup>2</sup> )	
Ver. Emp. Area (cm <sup>2</sup> )	

ADDITIONAL PARAMETERS	
Wing Aspect Ratio (or for equivalent wing in case of multiwings )	
Horizontal Tail Volume Coef.	
Vertical Tail Volume Coef.	

WEIGHT	kg
Aircraft Empty Weight	

This drawing (or plan) must be clearly identified with the name of the school, the number and the name of the team, in a key in the lower right-hand corner.

### 5.1.2.3. Additional Plans – Aircraft Disassembled in the Box.

As part of the procedure for checking the dimensions of the “Minimum Volume Box”, an additional set of plans must be sent, on A3 paper, containing the three views of the box, clearly showing how the aircraft is disassembled and packed in the box developed by the team. A copy of these plans must be bound with each copy of the Report. The plans must follow the recommendations described in item 2.9.5 (see example in Appendix 6.5).

This drawing must be clearly identified with the name of the school, the number and name of the team, in a key in the lower right-hand corner.

We recommend that these plans be the next-to-last of the seven plans bound in the Report (or plans 6).

It is indispensable that the table containing the INTERNAL dimensions of the box, as well as a list of the subsets, be present on these plans, in the upper right-hand corner, as shown in Appendix 6.5, page 80. The lack of this table could cause a penalty for the team, as set forth in Chapter 4, Section 4.3.1., item 7, page 52.

### 5.1.2.4. Plans – Open Class

Each team participating in the Open Class must turn in five (5) detailed copies of the plans of the airplane. **The plans consist of five (5) pages on A2 paper, printed on**



only one side, folded adequately (according to ABNT or ISO standards for **A2 paper**), which must be added and bound with the Report so that the judges can analyze them by merely opening them, without removing them from the Report.

A page should contain the drawing of three views, in standard aeronautical format, as described, above (Section 5.1.2.1, page 58, and Appendix 6.3, page 74). A perspective view of the aircraft ALSO can be inserted on this first page (above the side view), for a quicker visualization of the aircraft being presented. On the side of the page there should be a table with a summary of the airplane's data, always in the metric system.

We highly recommend that the drawing of the three views be the first of the five bound in the Report. We also recommend using, as a basic model table of the data of the aircraft, the one shown in Appendix 6.3, page 74. This Appendix is valid for the two Classes: Regular and Open. Additional data may be inserted into this table, if the team so desires.

The other four plans may follow the format of the drawings presented in any model airplane magazine.

**The objective of modifying the standard of the pages (from A3 to A2) is to give the teams an opportunity to present a larger number of views, cross-sections, and details, showing the variety of project and building solutions used on the aircraft.**

We do not recommend that drawings be sent that have merely by amplified, but, rather, a greater number of drawings and/or views per page, so that the judges can understand more clearly how the aircraft is composed of its several sets and systems.

At least one of the plans must show the cargo bay, with its dimensions.

We ask you to pay special attention to the structural details of the aircraft to be presented in the plans. These should be represented in such a way that they allow the judges and experts in the conceptual design and structures areas to have a complete visualization of how the main structural elements are built, such as a section of the wing spar, the wing-fuselage connection, tail cone and other pertinent items that belong to the functioning of this type of aircraft.

All of the pages of the plans should be marked with the name of the school, name and number of the team, in a key in the lower right-hand corner.

### 5.1.3. Summary – Required Documents

The team must send to SAE BRASIL, by the deadline specified for turning in the Reports:

- Five (5) bound sets each one containing: Cover or frontispiece, bound copy of the Liability Release, one copy of the Report (number of pages according to Regular or Open Class), one copy of the folded plans (5 pages) (including the two additional plans for the Regular Class), the graph of the estimated “useful load” (1 page), for the Open Class: the attached engine documentation (Section 3.2., page 31) and, if applicable, the document described in Section 1.8.2. (Reuse of the Airplane). *Note: These last two items (Sections 3.2. and 1.8.2) do not count as pages of the Report.*
- One (1) official size envelope identified with the name of the team, number and name of the school containing one copy of the Report required in Section 1.9.1 (if applicable) and one copy of the Report, as per Section 2.7.5., page 24.

All of the copies of the Report, plans and graph (and other applicable documents) must be identified with the name of the school, name and number of the team. We recommend inserting the number of the team legibly and in a visible place on the front cover or frontispiece of the Report, as presented in item 5.1.1.1., above.

The 5 bound sets are a necessary requisite to allow a larger number of judges to analyze each project.

The projects (Report, plans and graph) will not be corrected, but, rather, read, checked, discussed by the judges and given scores.

**The grades of the judges will be final and will not be reviewed.**

The feedback regarding each project may, during the Competition, be done in a variety of ways, as shown below:

- Questions during the oral presentation;
- Analysis by the team of the performance obtained by the airplane in the flight tests and trials;
- Comparative analysis of the airplanes of other teams and their performance during the Competition;
- Conversations with other teams;
- **Conversations with the judges during the Competition.** The members of the Technical Committee are also Competition judges and when possible, during the Competition, they could hold these conversations.

The team must pay close attention to the formatting rules, limitations on the Reports, plans, graphs, and oral presentation and dates, because not complying with these rules will result in points being taken away.

**Attention**

Officially, there is no maximum penalty attributed to the Reports. If a team receives total penalties (delays, formatting, dates, etc.), which are more than the highest grade Report, therefore generating a negative grade, the final grade of the team will be equal to zero.

The order to establish the final classification among the teams (or placement) will be set by the true value of the grades obtained, whether negative or not.

Example: A team obtained 100 points of the 165 maximum points attributed to the Report, but had total penalties of 115 points (for instance, 20 days late, (means a penalty of 100 points) + 5 extra pages (penalty of 10 points) + spacing not complying with the established format (penalty of 5 points)). The final unofficial or true grade of the team, in terms of the Report, will be -15 points, but, on the spreadsheet of the final results (or official results) the value will be shown as zero.

The same rationale will be applied to the oral presentations.

The Technical Committee understands that, unfortunately, cases like these could occur, but it is not of interest, from an academic and pedagogical point of view, that negative values be shown on the final scoring spreadsheet.

#### **5.1.4. Estimated “Useful Load” – Accuracy**

The graph of the estimated “useful load” (payload + payload assembly section weight) will be judged for its clarity and technical content, as well as the way in which the payload was estimated or predicted

The data must be linear, over a relevant range, and the graph **must include** the linear equation and the linear straight line.

Each team must provide five (5) copies on A4 paper of the graph of the **estimated “useful load” with the weight in kilograms (kg) x altitude-density in meters (m)**, according to the basic format given in Appendix 6.2. A copy of the graph must be bound with each copy of the Report.

Since these graphs will also be used to estimate the “useful load” during the Flight Competition, the team must turn in an additional copy, besides the five, separately, **with the linear equation and the linear straight line..** The graph must have the name of the team and school at the top, with the number **of the team also in the lower right-hand corner**. This must be done in landscape format.

We recommend paying special attention to the coherency of the plotted scale of the graph, that is, excessive altitudes do not apply.

### 5.1.4.1. Estimated Useful Load for Two Sections – Regular Class

If the aircraft in the Regular Class are operated in either of Sections 1 and 2 (see page 26, above), a graph of the estimated “Useful Load” must be sent, with two distinct curves for each of the respective Sections (Section 1: 30.5 meters and Section 2: 61 meters).

Repeating what was cited previously, if the team chooses to “operate” in only one of the Sections, thus sending only one accuracy curve, this score will not be counted, if the aircraft takes off in the other Section. Ex.: For an aircraft that has been designed to take off in 30.5 meters (or Section 1), but is able, for some reason, to take off only in Section 2 (61 meters), its accuracy points will not be taken into consideration, if the curve for Section 2 has not been sent in clearly and correctly.

A sample graph of the Estimated “Useful Load” for the two Sections is shown in the figure, below.

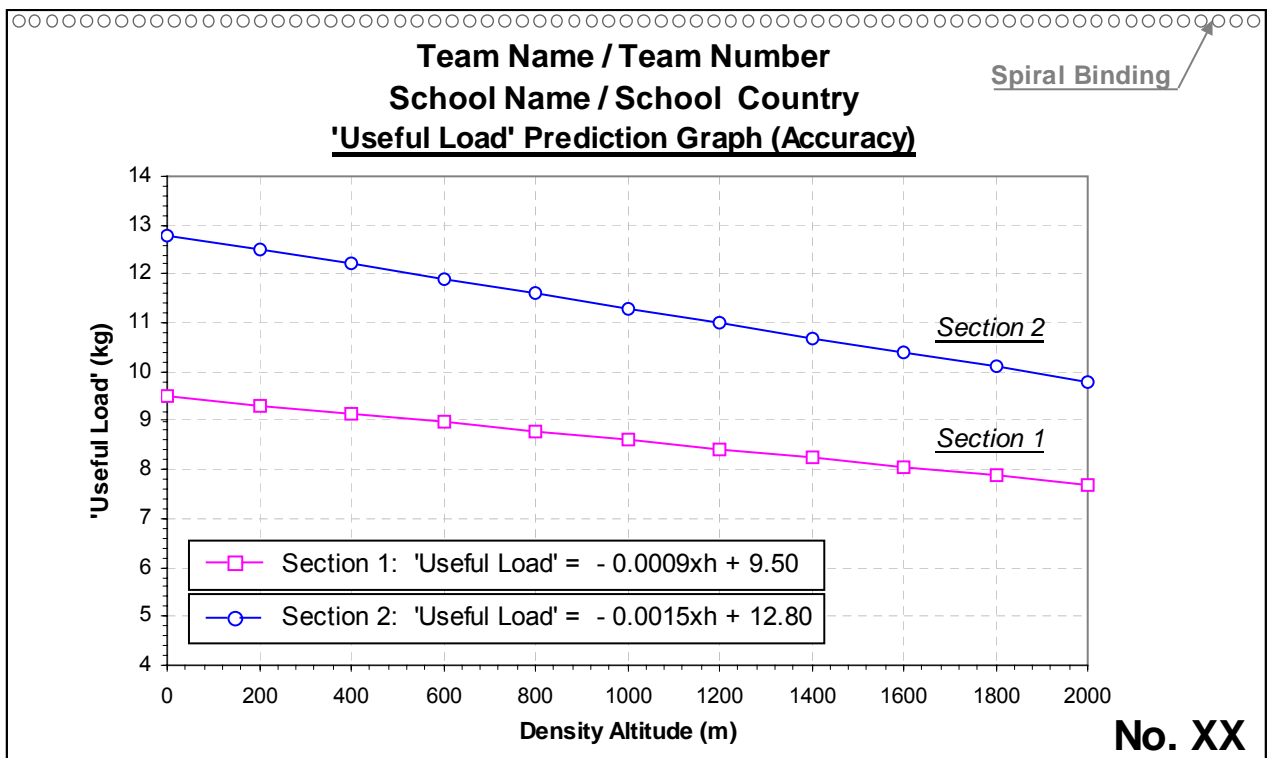

The Graph should be made as cited in Section 5.1.4, and should also be bound with the Report similarly to what is shown in the figure above.

### 5.1.5. Report Delay Penalties

The sets of Report, plans and graph of the estimated “useful load”, as well as the additional envelope, must be sent to the Technical Committee by the deadline date (Appendix 6.7). The Technical Committee or SAE BRASIL will not be liable for losses or address errors. We suggest that all of the Reports and plans be sent via SEDEX (Brazil, or registered overnight mail) (only in very special situations may these be delivered personally, but after consulting).

Only official stamps and receipts from the postal services will be accepted as proof of the date the Reports were sent.

The Reports, plans and graphs of estimated “useful load” sent in late will lose five (5) points per consecutive day (not business days).

The latest date for receiving the Reports will be 20 consecutive days after the deadline, corresponding to a penalty of 100 points.

**ATTENTION: ERRATA IN THE REPORTS, PLANS AND GRAPH ARE NOT PROVIDED FOR. Any document that arrives to the Committee as Errata or Correction of any type will not be considered. It is not feasible, from a logistical point of view, to allow errata. Only the original Reports will be delivered to the judges.**

**Eventually, a small correction could be accepted, only in the Graph of the Estimated “Useful Load” (Equation). This correction will be considered as a serious project modification and will be subject to the penalties to be set for each case.**

### 5.1.6. Notes on Delivering the Reports:

**Attention:** Most of the judges are on the technical staff of Embraer, and for that reason Embraer’s address is required. The sending, or personal delivery at the headquarters of SAE BRASIL, in São Paulo, or at any Regional Section of SAE BRASIL, is not considered valid, and will imply a heavy penalty.

**In order to resolve any doubts regarding the date for sending the Reports, WE RECOMMEND that the proof of sending, or at least a copy of it, be brought during the days of the Competition, unless it was sent along with the Reports.**

A week after the deadline for sending the Reports, or when most of them have arrived at the receiving address, the “registration process” will be performed. As a result of this registration, a spreadsheet showing all of the documents received, as well as their date of arrival, will be made available to the teams on the site, or by E-mail. It is important that everyone know what was registered by the judges of the Committee so that, in the case of eventual errors, they can be quickly corrected prior to the Competition.

**The deadline will be stipulated as the beginning of the week (Monday), and the teams that are a day late can send them the next day. The Reports that arrive with the date stamped by the postal services as being the Tuesday immediately following the deadline, will be penalized as one day late (or 5 points off).**

Parts of the Report, plans or graph sent in late will not be considered, that is, will not be delivered to the judges, therefore, they do not need to be sent.

For the purpose of the historic and technical records of the work of the team, on the part of the organizers and of the Technical Committee, the teams that are interested in sending, on the same CD requested in item 5.1.1, any additional files, like photos

of the team, of the construction of the aircraft, of the flights, or of any other item considered to be of interest for the records, will be very welcome to do so. These files are always useful for improving future Competitions, as well as for preparing new rules.

The confidential treatment given to the electronic copy will be even more rigid than what is given to the paper Reports.

Note: THE DATA RECORDED ON THE CD WILL NOT BE USED TO EVALUATE THE WORK OF THE TEAM.

### 5.1.7. Report Structure Model

The Project Report must contain no more than 35 pages (Regular Class) and 45 pages (Open Class), excluding **one** frontispiece (or cover), copy of the Liability Release, the document approving the reuse of the airplane, if applicable, (Section 1.8.2), plans, graph, and document required in Section 3.2 (Open Class). *These last two items (Sections 1.8.2 and 3.2.) do not count as pages of the Report. Therefore, they should not be numbered.*

A figure illustrating what this means is shown below, in Appendix 6.10, page 85.

The binding covers are highlighted in yellow, and they will not be counted. We highly recommend that the front cover be transparent, so as to permit reading the frontispiece (if it is not transparent, it must contain the following information: name of the school, name and number of the team). This frontispiece, whether protected or not by a plastic cover will not be counted as a page of the Report.

**We recommend that, according to the availability of the team, the Reports be bound with a spiral back and plastic covers. This facilitates handling and reading.**

### 5.1.8. Oral Presentation

The oral presentation will be open to teams participating in the Competition, as long as they do not interfere with or jeopardize the presentation taking place. For the team that is making its presentation, only one student will be allowed to present at a time. The interference of other members will be permitted, as long as they are appropriately indicated and introduced by the presenter. The presentation by more than one member of the team will be allowed, as long as the changes of presenters are previously established at the beginning of the presentation and are done in an organized fashion.

The interference of professors or advisers of the school will not be allowed and, if they occur, the team will be heavily penalized.

Each team will have fifteen (15) minutes for the presentation of their project. The criteria for judging the presentation include defining the objectives of the project, describing the efforts made to achieve those objectives and the results obtained. The quality of the presentation is also an important part of the score. **The airplane must be completely assembled and be taken to the presentation for the judges to examine.** For the airplanes of the Open Class, we recommend that the complete airplane be taken to the room of the oral presentation (even if disassembled), but, due to the dimensions of the aircraft, this could turn out to not be very practical.

After the presentation, the judges will have ten (10) minutes (point of reference) to ask questions regarding the project.

The order of the oral presentations will be established in good time (on SAE's site). When possible, the presentations of the teams from the same school will take place in the same room, at consecutive times.

There will be an overhead projector and screen in each presentation room. The use of a datashow, videotape player, slide projector, multimedia projector, flip charts, chalk board or white board, and other audiovisual resources are allowed, but the availability of the equipment, as well as checking on the existence of electrical outlets, switches, adequate lighting, screen, supports, or other resources will be up to the teams and they must be ready to use before the presentation. The maximum time for installing these resources will be two (2) minutes. The team that is late, due to error, lack of electrical outlets, or a delay in installing the equipment, doing the setup, etc., will be penalized. Two (2) minutes after the team enters the presentation room, the fifteen (15) minutes allowed for the presentation will begin. An eventual delay in taking down the equipment could also be penalized.

The presentation must be done live. If the team decides to show recorded material, it will only be allowed to show movies of flights, tests, and simulations, but the narration must be live and not recorded. Background music will be allowed.

The confirmation of audiovisual resources that will be available for the teams will be communicated up to one (1) week before the event to all of the teams, via the Procedures and Conduct Manual. SAE BRASIL will do everything possible to make multimedia projectors and computers available for the oral presentations, as it has done in previous Competitions, but this is not a commitment, since the cost of renting this equipment is high. Because renting this equipment is per day, there is no way to make them available a day early for tests or checks. We know that there is equipment, more or less modern, with different types of connectors. Each presentation room could differ, in terms of equipment model, therefore some might offer several types of connectors and other equipment could have only the most common type of connector. We suggest that the teams that intend to use this resource be prepared for this, in order to avoid last-minute surprises.

We also suggest that they come with transparencies, to fill in if the multimedia projector bulb burns out or the machine breaks down.

## **6. APPENDIXES**

<b>6.1. Regarding the Compartment, “Payload Assembly Section” and Payload</b>	
6.1.A Example of the “Payload Assembly Section” .....	70
6.1.B Example of the “Payload Assembly Section” (Three Views) ....	71
6.1.C Additional Comments .....	72
<b>6.2. Examples of the Estimated “Useful Load” Graph ...</b>	<b>75</b>
<b>6.3. Drawing in Three Views .....</b>	<b>76</b>
<b>6.4. Dimensional Inspection .....</b>	<b>77</b>
6.4.A Geometric Restrictions – Additional Information .....	77
6.4.B Identifying the “Surface Groups” – Examples .....	79
6.4.C Three Additional Views – Dimensional Inspection.....	81
<b>6.5. “Minimum Volume Box” – Example .....</b>	<b>82</b>
<b>6.6. Liability Release .....</b>	<b>83</b>
<b>6.7. Registration Deadlines .....</b>	<b>84</b>
<b>6.8. Liability Release – Change of Pilot .....</b>	<b>85</b>
<b>6.9. Declaration that the airplane has already flown .....</b>	<b>86</b>
<b>6.10. Example of Design Report Structure.....</b>	<b>86</b>

**APPENDIX – 6.1A: EXAMPLE OF “ASSEMBLY SECTION” AND  
“PAYLOAD”.**

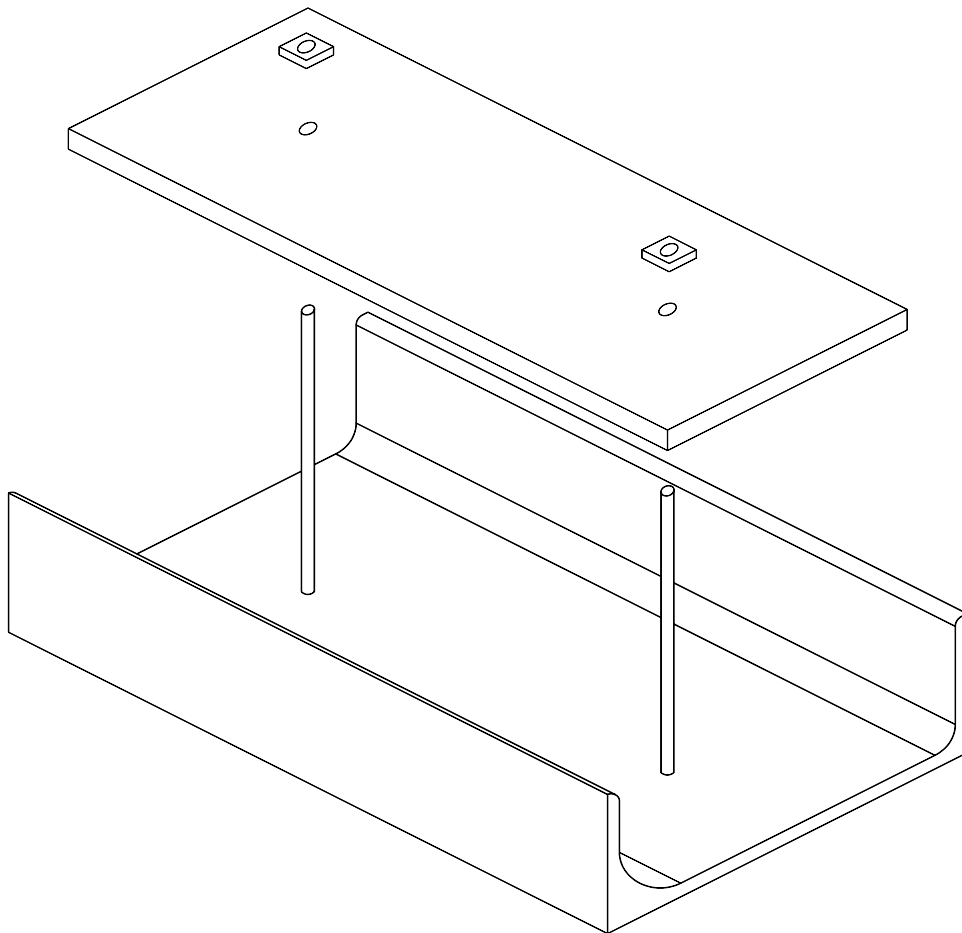

This group, in the AeroDesign Brazil, is know as “Payload Group” or “**Useful Load**”



**APPENDIX – 6.1B: “PAYLOAD ASSEMBLY SECTION” – Example**  
(the dimensions shown below are merely illustrative)

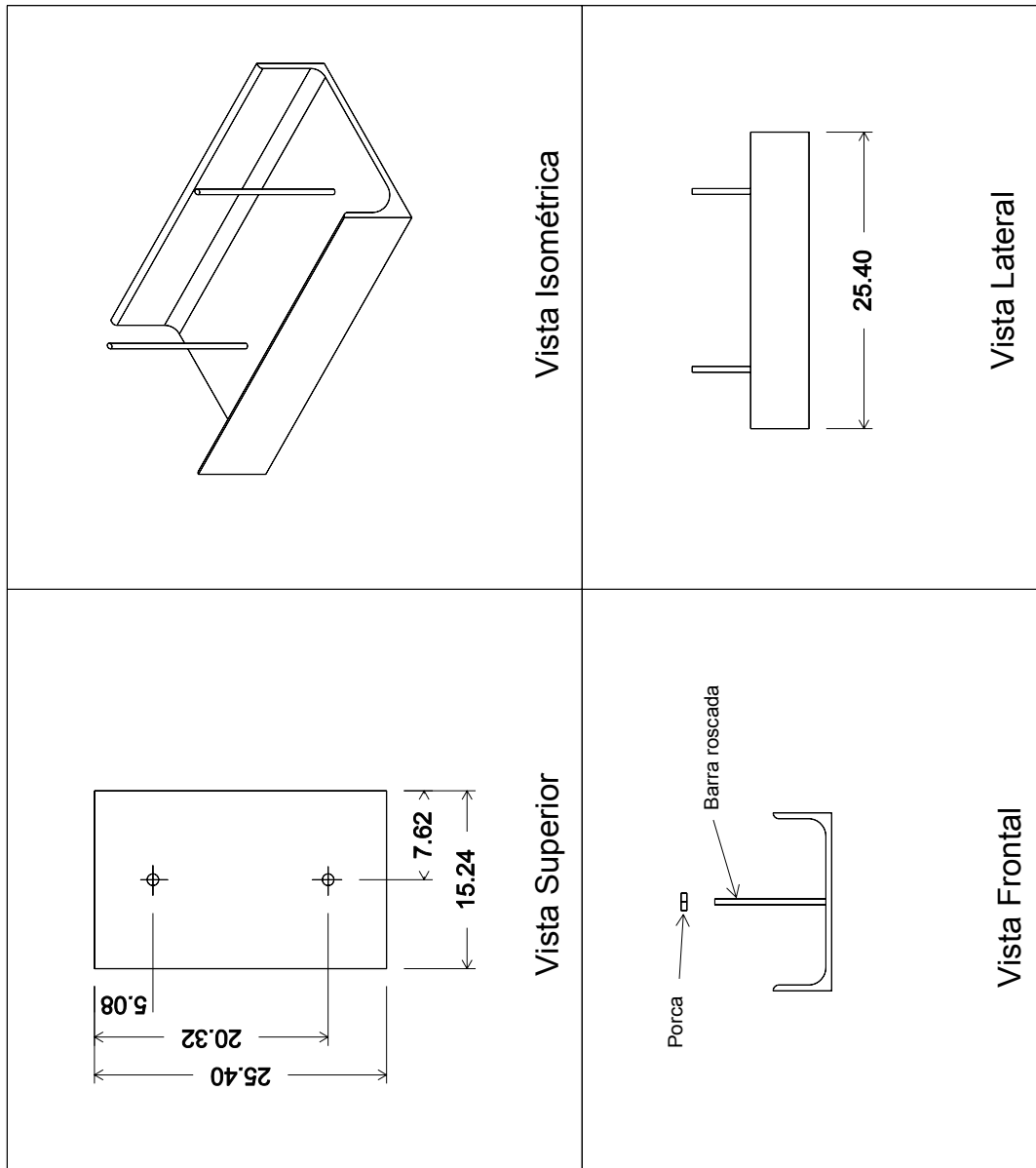

- |                  |   |                |
|------------------|---|----------------|
| Vista Isométrica | → | Isometric View |
| Vista Lateral    | → | Lateral View   |
| Vista Superior   | → | Plan View      |
| Vista Frontal    | → | Frontal View   |

## **APPENDIX – 6.1C: ADDITIONAL EXPLANATIONS – Cargo Compartment.**

**Objective:** define the main components of the cargo compartment (or cargo bay), with their function and how they work.

### **Preliminary Definitions:**

**Cargo compartment:** Internal volume of the aircraft where the “Payload Assembly Section” and the “Payload” are stored. This volume is established by the dimensions set in the Regulations, or 110 x 160 x 350 mm (4.33 x 6.30 x 13.78 inches).

**“Payload Assembly Section”:** Element that will contain the payload bars to be transported. This assembly section will be fastened to the structure when mounted inside the compartment, and on the ground. This should be done so that it can be removed through an opening in the aircraft. This opening should be closed with a door (or even with a lid) which is separate from the assembly section. This assembly section can be weighed along with the payload plates, that is, it counts as a part of the “useful load”. The “payload assembly section” CANNOT contribute to the structure of the aircraft, that is, the structural integrity of the aircraft should be ensured without needing the assembly section!

**Payload:** Bars of lead (or steel) carried by the aircraft and fastened to the “payload assembly section”

**Cargo Bay Door:** Element or part of the aircraft used to close the cargo bay. We recommend that it be a structured or rigid element. This lid or door cannot be destroyed or damaged during the process of “quick payload removal” (item 2.9.4 of the Regulations).

**“Payload Assembly Section Lock”:** A device for fastening the “payload group” (payload assembly section + payload) inside the cargo bay, to the structure of the aircraft, so as to keep it from making any movement during the several flight phases. If this device is a part of the “payload assembly section”, it is considered as part of “payload group” than can be weighed as “useful load”.

**Cargo Bay Door Lock:** A device for fastening the door of the compartment in the closed position. It may or may not be activated by the “payload assembly section lock”, but should allow independently closing the door.

The cargo bay should be built to hold a rigid block of at least 110 x 160 x 350 mm (4.33 x 6.30 x 13.78 inches). The door or lid must not be a part of the “payload assembly section”, because the block must fit into the closed cargo bay, without interfering with any part of the aircraft. According to item 2.5 of the Regulations of the Competition, the standard block will be rigid (made of wood) and there may be no interference of any element of the cargo bay with the volume represented by the standard block. Screws, cabling or any other element that interferes with entirely inserting the standard rigid block into the limits established by the Regulations, will cause the compartment to be considered outside of the minimum limits and, therefore, the flight will be considered invalid.

The assembly section should be fastened to the structure of the aircraft at points that are sufficiently rigid to not allow the movement of the “payload group”, whatever the flight situation. No solutions will be accepted where fastening the “payload group” is only on the lid (or door) unless there is an analysis that shows that these components can resist the loads applied on this part of the aircraft under any flight conditions. The fastener of the assembly section in the compartment can be a part of this assembly or a part of the aircraft.

The lock mechanism of the assembly section can activate the lock of the door, but the latter must be able to be closed with the standard block totally installed in the cargo bay. In other words, the door can be activated by the mechanism of the assembly section lock, but should be able to close the door of the compartment without the assembly section.

The “payload assembly section”, the cargo bay door, and the mechanism of the assembly section lock must be clearly presented in one of the sets of plans, so as to facilitate an understanding of how they function.

Since the main objective of AeroDesign is educational, an additional challenge intrinsic to the project was created, in 2002, consisting of a study needed for correctly positioning the Center of Gravity (CG) of the aircraft with any payload (empty, classification payload or maximum payload) without, however, changing the position of the payload bars in relation to the “payload assembly section” (it is prohibited to use asymmetric payload bars (see figure below)). In all situations, the aircraft should be able to fly safely. The Technical Committee considers that using an asymmetric distribution of payload bars is a very trivial solution that does not accrue value, from the standpoint of a project challenge. Therefore, the bars must be distributed uniformly (or symmetrically), as shown in the figure, below.

For this reason, item 2.5.1. requires that the distribution of the payload bars be symmetrical or uniform. This means that all payload bars, positioned in the assembly section, must show its CG (CG – payload bars) vertically aligned with the CG of the assembly section (CG – assembly section). Small variations in this alignment are permitted since the assembly section often has devices or other elements that slightly change its CG position.

The movement of any CG adjustments, of the whole “payload group” (useful load) inside, for example, a bigger cargo bay (compared to the minimum required), is permitted.

The following figures show several examples of what is **permitted** and what is **not accepted**.

**Uniform (or **symmetrical**) payload distribution**

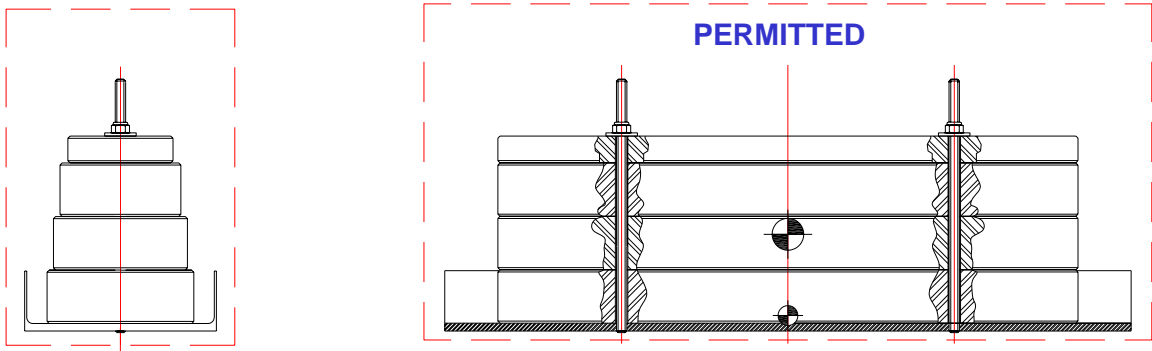

Non uniform (or **assymmetric**) payload distribution

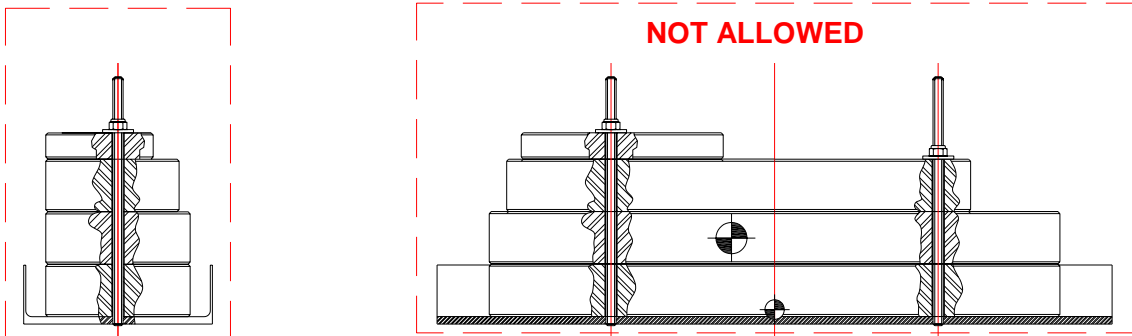

In order to better consolidate and understand the definitions presented, above, it is important to draw a parallel between the requirements of the Regulations of AeroDesign Brasil and, for example, the design of a cargo bay for a military cargo transport aircraft (Ex.: Lockheed C-130 Hercules).

Let us consider:

1. The cargo bay of a military aircraft usually has its dimension set by what it intends to carry (ex.: military vehicles). Therefore, there can be no interference between the maximum limits of this vehicle and the internal dimensions of the compartment.  
*At AeroDesign, these minimum dimensions are set by the Regulations.*
2. The cargo bay of the military aircraft must logically have a door, or at least an aerodynamic fairing closing the cargo bay. On the occasions when the aircraft is flying without cargo, the cargo bay must be closed, therefore the cargo door (or lid) must be a part of the aircraft.  
*For the aircraft of AeroDesign, in a situation where the “payload group” are not inside the cargo bay, like, for example, during the check of the dimensions of the compartment, it must be totally closed, that is, it must have a door or a lid! The block of wood must be inside when the compartment is totally closed.*
3. Closing the cargo bay of military aircraft is done, usually, with a structural element (or fairing) that is a part of the aircraft and not of the cargo. We have not heard of a cargo that has the door of the bay, attached to it.  
*For this reason, we highly recommend that the cargo bay door of the aircraft of AeroDesign be a part of the aircraft and not of the payload assembly section as seen in past years. This solution is aerodynamically more elegant and realistic. The door can eventually be removed completely from the aircraft, but its integrity should be maintained. The same door must be used, later, for closing.*
4. During the unloading process, for example, even when done quickly, the integrity of the door should be maintained so as to allow the aircraft to fly after unloading.  
*For this reason, at AeroDesign, during the process of “quick payload removal”, it is prohibited to damage the door (or lid) of the cargo bay of the aircraft, even accidentally. The total integrity of the aircraft should be maintained so that the score for the Cargo Removal Time can be calculated.*

**APPENDIX – 6.2: SAMPLE GRAPH OF ESTIMATED “USEFUL LOAD”**

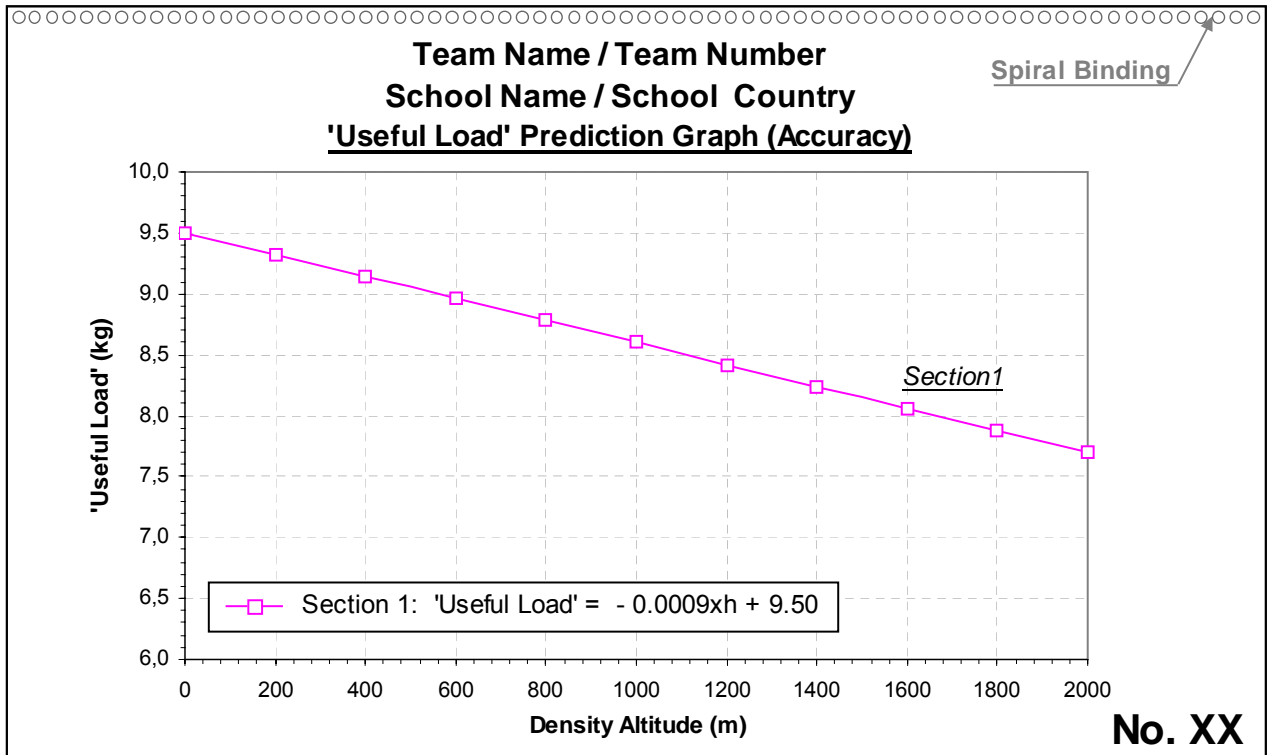
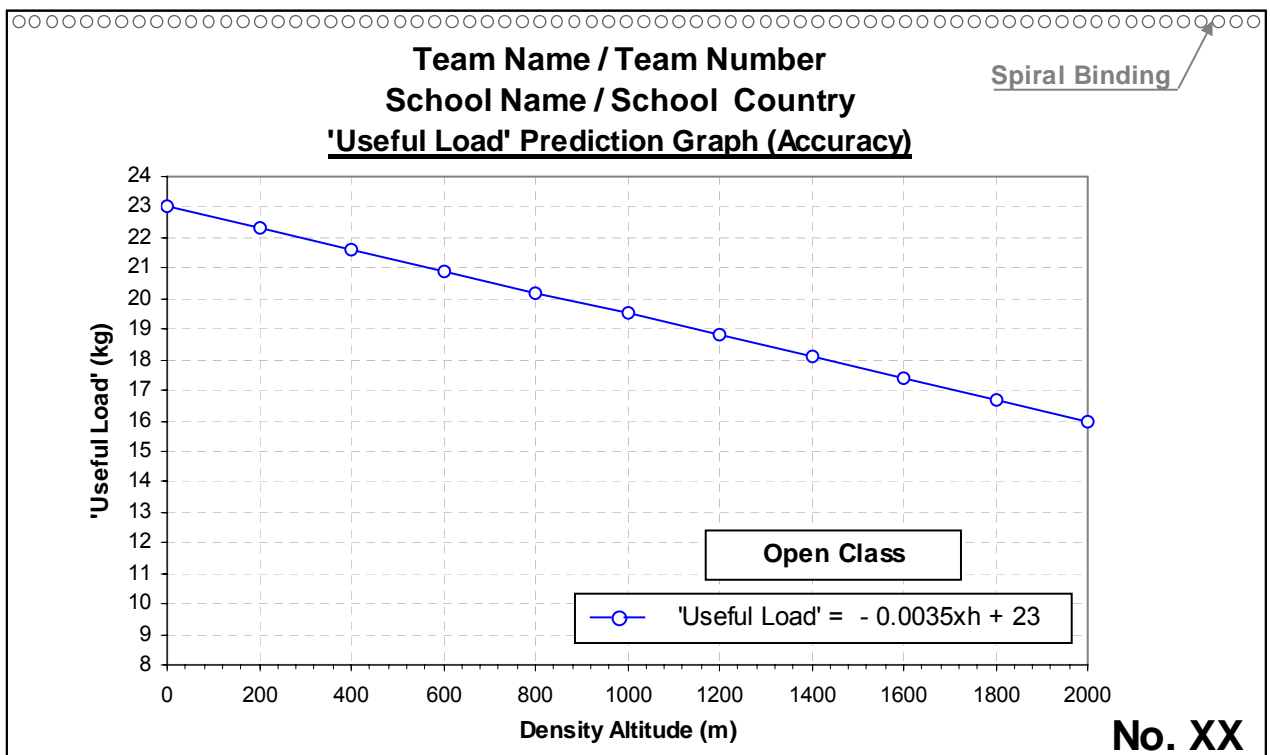

Figure above: Sample Regular Class graph for Section 1, only. See Section 5.1.5.1.



Bind as indicated in this figure. The graph should be in landscape format.

Figure above: Sample Graph for the Open Class. See Section 5.1.5.1.

The segmented takeoff is not valid for the Open Class. Either a normal or 61-meter runway will be used.

Bind as indicated in this figure. The graph should be in landscape format.

## APPENDIX – 6.3: DRAWING IN THREE VIEWS

(put the dimensions in the International System)

Inserted dimensions: team decision

Team number / Team Name	Maximum Dimensions (values em mm)
L	Maximum Length (mm)
H	Maximum Height (mm)
B <sub>1</sub>	Biggest Span - Group 1' (mm)
B <sub>2</sub>	Biggest Span - Group 2' (mm)
...	...
B <sub>n</sub>	Biggest Span - Group 'n' (mm)
Dimensions Total (mm) ▲	
Area em cm <sup>2</sup>	
WING	Wing Area (cm <sup>2</sup> )
	Wing Aspect Ratio (or calculation wing for multiblade)
	Aerodynamic Airfoil
HORIZONTAL TAIL (HT)	
	HT Area (cm <sup>2</sup> )
	HT Aspect Ratio
	HT Aerodynamic Airfoil
	HOR. Tail Volume Coef.
VERTICAL TAIL (VT)	
	VT Area (cm <sup>2</sup> )
	VT Aspect Ratio
	VT Aerodynamic Airfoil
	VERT. Tail Volume Coef.
	Aircraft Empty Weight (kg)

Top View

Side View

Front View

**Drawing Key**  
 Suggestion: Insert here at least, the name of the school, name and number of the team, name of draftsman, and drawing scale

Sample mandatory table. More information can be added.  
 We suggest citing at least MLG track, MLG base, L, H, B<sub>1</sub> and B<sub>2</sub>

74

## **APPENDIX – 6.4A: GEOMETRIC RESTRICTIONS: Additional Information**

- i) The maximum length, or “**L**”, will be considered as the biggest dimension found of the aircraft along the X axis, or along its central line. This dimension can be, for example, from the spinner to the point most aft on the vertical tail, or between any of the outer points that mark the maximum length taken by the aircraft. It is mandatory to use a spinner.

This maximum length, as already mentioned in Section 2.2.1., page 15, is measured parallel to the ground (or Reference Surface) and the symmetry plane (or X axis) of the aircraft. The most extreme points for checking the maximum length, must not necessarily be on the same plane. They may be on separate planes, but always parallel to the symmetry plane of the aircraft or central line of the aircraft.

- ii) The maximum height, or “**H**”, is the biggest dimension found perpendicularly to the reference surface (or ground) up to the highest point of the aircraft. This highest point can be either a surface or some other element that marks an imaginary plane parallel to the reference surface.

The dimension “**H**” can vary coherently with the cargo due to the deflection of the landing gear, but during height check, the aircraft MUST be totally empty, that is, without the “payload group”. Therefore, the landing gear must be at its minimum deflection.

- iii) The dimension “**B<sub>i</sub>**”, is the span or the maximum width projected in the plan view (upper view) of the largest element of each of the “group of aerodynamic surfaces”.

This measurement will be taken between the most extreme points of each of the “groups”, for example, winglets, rounded wingtips, endplates, or any point farthest out of this “group”.

**Example 1:** for the case of an “H” tail configuration, the considered span will be the most external measurements of the vertical tails (or on the outside of the “H”).

**Example 2:** for the case of V-shaped tail sections, or with a dihedral, the measurement considered will be that of the projected span on the plan view of the aircraft.

**Example 3:** for swept wings or tails, the span measurement will, logically, be that between the tips, or the maximum width of the “group of surfaces”.

For example, for a conventional monoplane aircraft, with two “groups of aerodynamic surfaces”, the three biggest dimensions defined above: maximum length (“**L**”), maximum height (“**H**”) and maximum wingspan (“**B<sub>1</sub>**”), establish six plans that form a “rectangular prism” (or “virtual hangar”) where the aircraft should be TOTALLY inserted. The “fourth dimension” will be the span of the horizontal tail surface (or “**B<sub>2</sub>**”).

The sum of “**L**” + “**H**” + “**B<sub>1</sub>**” + “**B<sub>2</sub>**” must, therefore, be EQUAL to 6.5 meters.

---

**Attention:** Overlapped cases for “multi-element” airfoils should be evaluated by the Technical Committee. If the team decides to use “multi-element” airfoils (for example, with flaps or slats), they **MUST** send an E-mail to [vanessa.viana@saebrasil.org.br](mailto:vanessa.viana@saebrasil.org.br), with detailed drawings of the geometrical solutions, such as flaps and slat proportions compared to the airfoil local chord. All cases in this situation, or similar, will be evaluated by the Technical Committee.

**iv) How to correctly interpret the combination of “groups of aerodynamic surfaces”**

Consider the example, below, (based on figure 1, page 16), where there is no overlap of all four surfaces and each one has a given span.

As is always considered in each “group”, the value (or span) of the largest element, there are two possible combinations of “surface groups”.

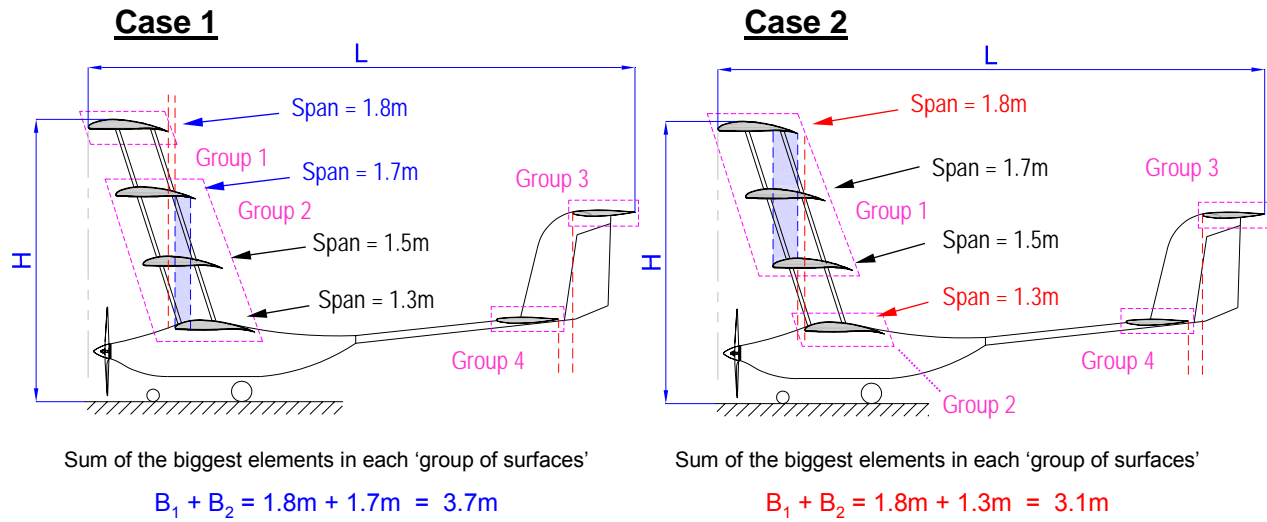

The chosen combination will be the one that gives the highest value of  $B_1 + B_2$ , or 3.7m. The correct combination is shown in Case 1.  
Total: “L” + “H” + 3.7 meters + “B<sub>3</sub>” + “B<sub>4</sub>” = 6.5 meters

In this way, repeating what was cited in Section 2.2.1, page 15, in the paragraph in **bold print**, the team must always consider the worst-case scenario or that which determines the largest sum of the dimensions.

**Cases which are considered to be more specific and are not described or covered by these Regulations, must be informed to the Technical Committee as far in advance as possible. Please send a drawing so that the concept can be evaluated in the most adequate manner.**

With this new dimensional restriction, the objective of the Technical Committee is not only to establish new challenges for the Teams, but also to make them develop methods or algorithms for optimizing their aircraft without, however, inhibiting the presentation of new and possible configurations. The existence of the possibility of overlapping the aerodynamic surfaces within the maximum amount of 6.5 meters was allowed, exactly, for creating the “benefit of the doubt”, that is, making all of the participants study which would be the best aircraft for completing the mission. This “doubt” has no single, much less trivial, answer.



**APPENDIX – 6.4B: IDENTIFYING THE “GROUPS OF AERODYMANIC SURFACES” – Aircraft Examples**

In order to consolidate the correct interpretation of the number of “groups of aerodynamic surfaces”, several historical examples of aircraft were chosen with their respective number of “groups”. *These are merely illustrative and didactic examples, and not necessarily appropriate for AeroDesign!*

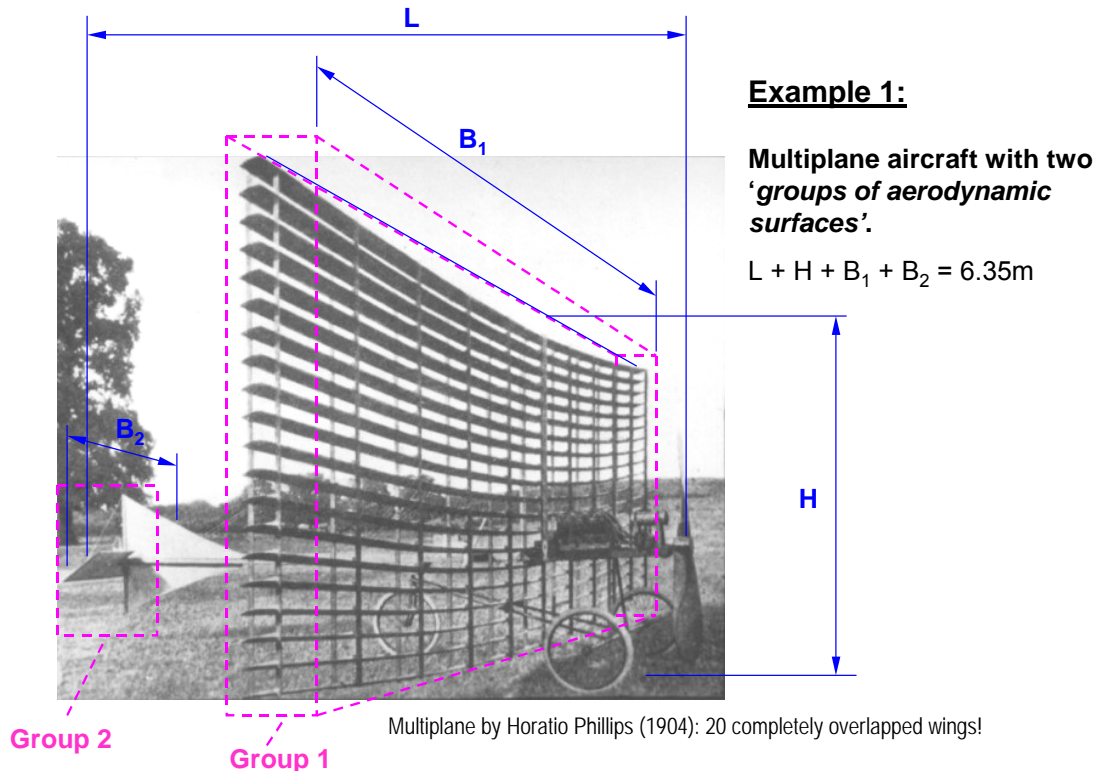

**Example 2:** Multiplane aircraft with three ‘groups of aerodynamic surfaces’.  
 $L + H + B_1 + B_2 + B_3 = 6.35m$

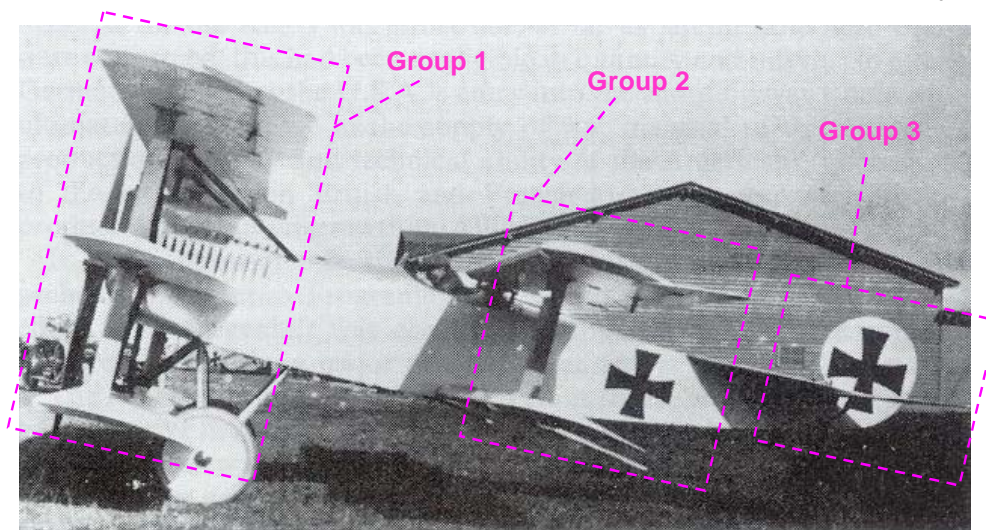

The Fokker V.8 quintuplane (1921).

**Group 1:** Three forward mutually overlapped wings.

**Group 2:** Two rear overlapped wings.

For  $B_1$  and  $B_2$  values: considered the biggest span in each group.

**Group 3:** Horizontal tail.

**Example 3:** Multiplane aircraft with three 'groups of aerodynamic surfaces'.  
 $L + H + B_1 + B_2 + B_3 = 6.35\text{m}$

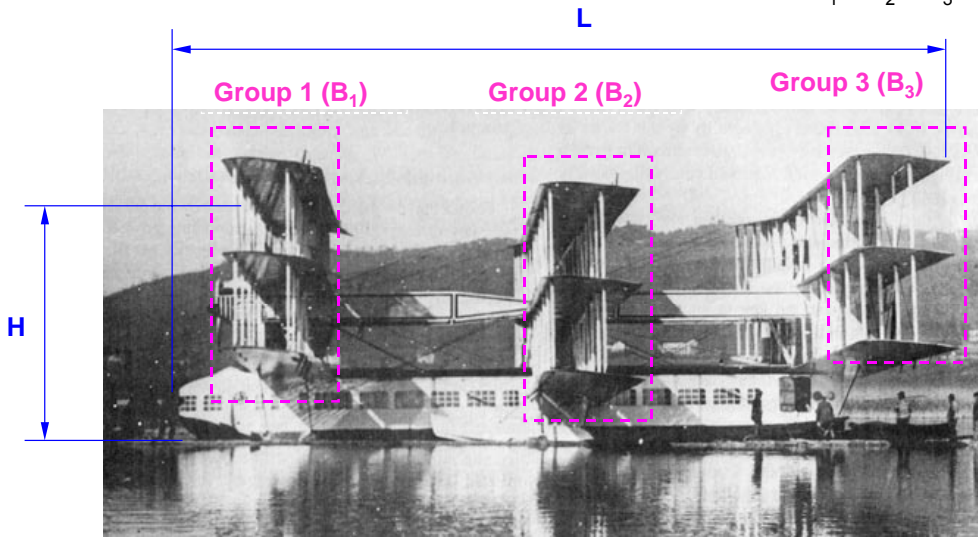

Caproni Ca-60 Capronissimo (1921) : "Flying boat" for 100 passengers.

**Example 4:** Aircraft with one 'group of aerodynamic surfaces'.  $L + H + B_1 = 6.35\text{m}$

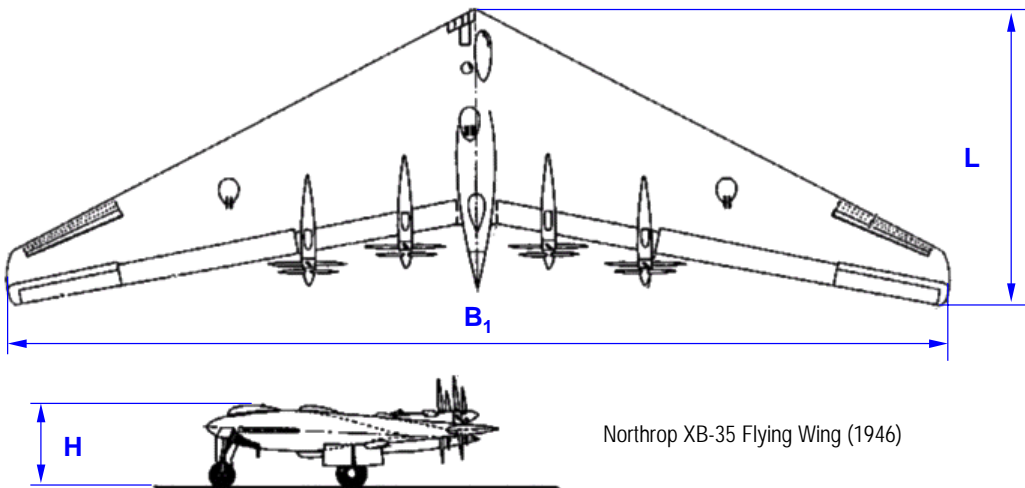

Northrop XB-35 Flying Wing (1946)

**Example 5:** Tandem wing aircraft with three groups of aerodynamic surfaces'.  
 $L + H + B_1 + B_2 + B_3 = 6.35\text{m}$

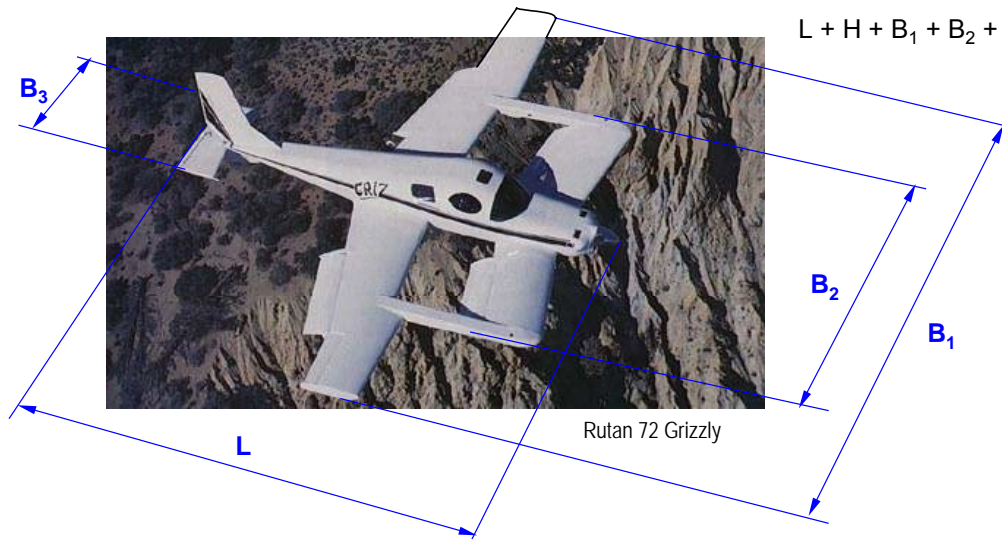

Rutan 72 Grizzly

## APPENDIX – 6.4C: THREE ADDITIONAL VIEWS – Dimensional inspection

Aircraft example and its main dimensions. A-3 paper.

**INSERT IN THIS DRAWING ONLY  
THE MAIN DIMENSIONS USED FOR  
DIMENSIONAL VERIFICATION**

**Sample Configuration**  
Conventional aircraft with two groups of aerodynamic surfaces (one surface for each group)  
Total:  $L + H + B_1 + B_2 = 6350\text{mm}$  (or 6.35m)

Team Number / Team Name	
Maximum Dimensions <i>(insert values in mm)</i>	
L	Maximum Length (mm)
H	Maximum Height (mm)
B <sub>1</sub>	Biggest Span - 'Group 1' (mm)
B <sub>2</sub>	Biggest Span - 'Group 2' (mm)
...	...
B <sub>n</sub>	Biggest Span - 'Group n' (mm)
Dimensions Total (mm) ▲	
ITEM	Area in cm <sup>2</sup>
Wing Area	(cm <sup>2</sup> )
Hor. Emp. Area	(cm <sup>2</sup> )
Ver. Emp. Area	(cm <sup>2</sup> )
ADDITIONAL PARAMETERS	
Wing Aspect Ratio <small>(or for equivalent wing in case of multiwings)</small>	
Horizontal Tail Volume Coef.	
Vertical Tail Volume Coef.	
WEIGHT	kg
Aircraft Empty Weight	

Please indicate the 'groups'!

**Drawing Key**  
Suggestion: Insert here at least, the name of the school, name and number of the team, name of craftsman, and drawing scale

Bind an additional set of the drawings (A3) with each of the five copies of the Report.  
**Cite only the main dimensions: H, L, B<sub>1</sub>, B<sub>2</sub>, to B<sub>n</sub>.**

## APPENDIX – 6.5: THREE ADDITIONAL VIEWS – “Minimum Volume Box”.

Example of aircraft disassembled, in the box. A-3 paper.

Team Number / Team Name	
Box Internal Dimensions	cm
Length (L)	00.00
Width (W)	00.00
Height (H)	00.00
Internal Volume (L x W x H)	cm <sup>3</sup> ou m <sup>3</sup>
00.00	
Number of subsets (or elements) in the box	XX
Elements or Subsets List	
Fuselage + engine	
Complete wing group	
Main landing gear group	
Horizontal tail group	
etc.	
...	

**Drawing Key**  
Suggestion: Insert here, at least, the name of the school, name and number of the team, name of draftsman, and drawing scale

This empty space in the sheet may be used to insert a 3D drawing with the aircraft disassembled inside the box

Internal Length (L) (cm)

Internal Width (W) (cm)

Internal Height (H) (cm)

Bind an additional set of the drawings (A3) with each of the five copies of the Report.

**APPENDIX – 6.6: STATEMENT OF RESPONSABILITY**

Team Name: \_\_\_\_\_ Team Number: \_\_\_\_\_

School: \_\_\_\_\_

School Authority: \_\_\_\_\_

E-mail: \_\_\_\_\_

**STATEMENT OF RESPONSABILITY**

As the responsible person for this school, I hereby certify that the members of the team are regularly enrolled students of the Engineering, Physics or Aeronautical Sciences courses. This team projected, built or modified a radio-controlled airplane that will be used for the SAE BRASIL AeroDesign Competition 2008, without direct assistance from professors or professional engineers, model airplane builders, pilots or related professionals. **If this airplane has competed in previous years, the Project Report will include sufficient documentation to prove that this was significantly modified. The members indicated with an asterisk participated on teams in previous years. A copy of this Release is included as a second page of the Project Report.**

\_\_\_\_\_  
Signature of the School Authority

**Team:**

Captain:	Name _____	Signature _____
Pilot:	Name _____	Signature _____
Members:	Name _____	Signature _____
	Name _____	Signature _____
	Name _____	Signature _____
	Name _____	Signature _____
	Name _____	Signature _____
	Name _____	Signature _____
	Name _____	Signature _____
	Name _____	Signature _____
	Name _____	Signature _____
	Name _____	Signature _____

**APPENDIX – 6.7: DEADLINES**

1. Turn in Registration Form	<b>TBD</b> Possibly in April
2. Turn in the Report + CD, Drawings and Graph of the Estimated "Useful Load".	<b>July 21, 2008</b>
3. Beginning of the Competition (oral presentation)	<b>October 16, 2008</b>
4. Flight Competition	<b>October 17, 18 and 19, 2008</b>

**FOR BEING LATE IN TURNING IN THE REPORT AND DRAWINGS, THE TEAM WILL LOSE FIVE (5) POINTS PER DAY.**

**TBD = To Be Defined**

**APPENDIX – 6.8: LIABILITY RELEASE FOR CHANGING THE PILOT**

Team Name: \_\_\_\_\_ Team Number: \_\_\_\_\_

School: \_\_\_\_\_

School Authority: \_\_\_\_\_

E-mail: \_\_\_\_\_

**Information on Changing the Pilot**

Name of the Previous Pilot	
Name of the Substitute Pilot	

**LIABILITY RELEASE FOR CHANGING THE PILOT**

As the person responsible for the School, I hereby certify that the members of the team accept the Substitute Pilot indicated for Flight SAE BRASIL AeroDesign Competition 2008 flight, knowing the inherent risks and exempting SAE BRASIL of any liability for eventual accidents.

\_\_\_\_\_  
Signature of the School Authority

**APPENDIX – 6.9: DECLARATION THAT THE AIRPLANE ALREADY FLEW**

**DECLARATION THAT THE AIRPLANE HAS ALREADY FLOWN**

Team Name: \_\_\_\_\_ Team Number: \_\_\_\_\_

School: \_\_\_\_\_

Team Adviser: \_\_\_\_\_

As the person responsible, from the School, I hereby certify that the airplane designed by the members of the team has already performed at least one complete and safe flight under the conditions in which it was taken to the Competition (after any significant repairs were made). I am aware of the importance of this declaration for the safety of the participants in the event.

Date of last flight taken: \_\_\_\_/\_\_\_\_/\_\_\_\_

\_\_\_\_\_  
 Signature of Team Adviser

Date: \_\_\_\_/\_\_\_\_/\_\_\_\_

\_\_\_\_\_  
 Signature of the School Director

**Team:**

Captain:	Name _____	Signature _____
Pilot:	Name _____	Signature _____
Members:	Name _____	Signature _____
	Name _____	Signature _____
	Name _____	Signature _____
	Name _____	Signature _____
	Name _____	Signature _____
	Name _____	Signature _____
	Name _____	Signature _____
	Name _____	Signature _____
	Name _____	Signature _____



## APPENDIX – 6.10: EXAMPLE OF THE DESIGN REPORT STRUCTURE

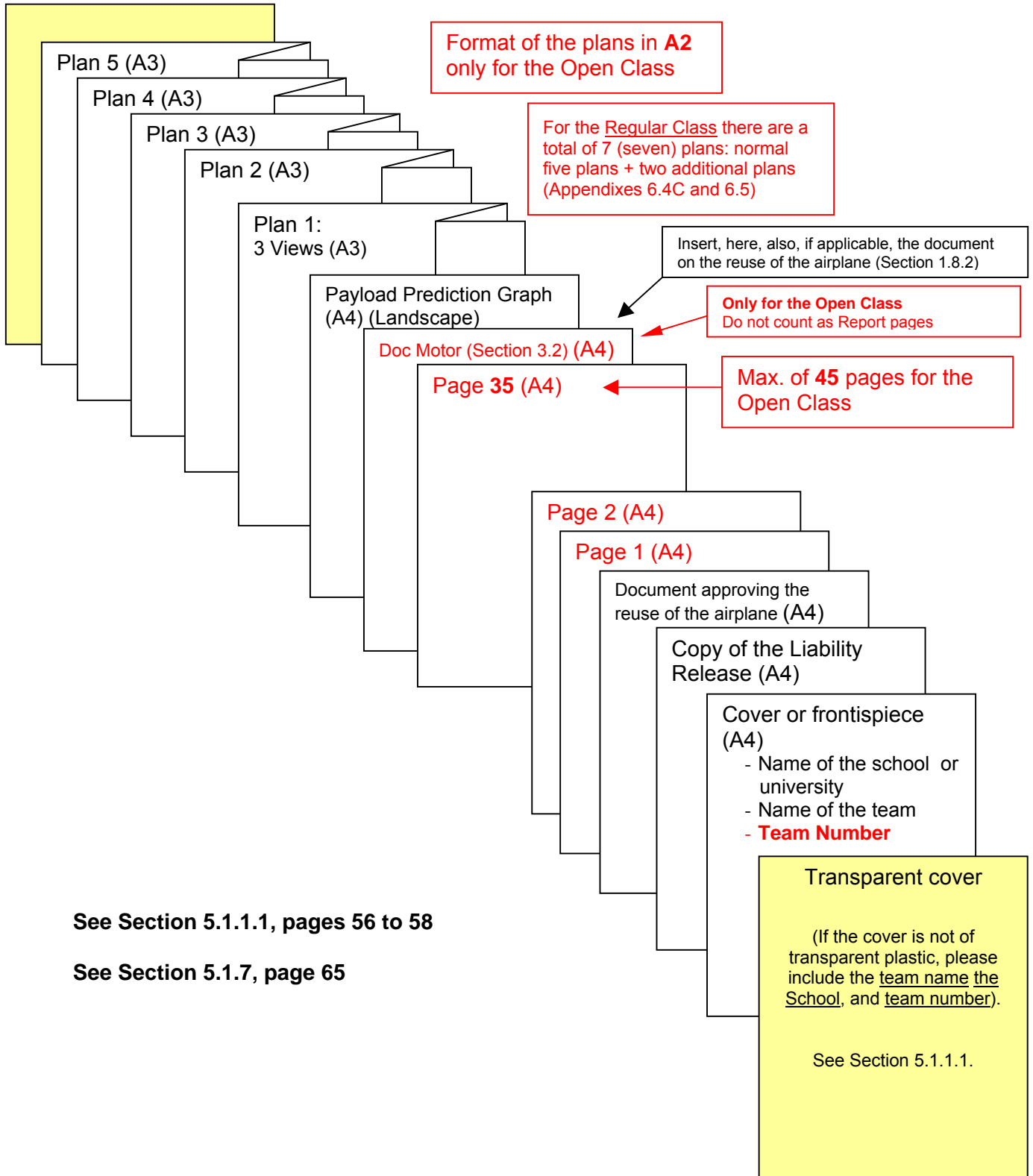

See Section 5.1.1.1, pages 56 to 58

See Section 5.1.7, page 65